

IOT BASED ADVANCE TECHNIQUE FOR DETECTION OF VEINS FOR EASY AND SAFE INTRA VEINUS INJECTION OF MEDICINE

¹AKANKSHA PRABHUDAS WELE, ²PALLAVI PRAKASH GHOGARE

¹M-tech in Electronics Design and Technology · ²M-tech in Electronics Design and Technology

¹ National Institute of Electronics and Information Technology, Aurangabad, Maharashtra ,India

Abstract— In medical field there will be a problem that vein of weak patient will not be visible. Due to not able to find vein, doctors face many problems to give Intra vein medicine to patient such as injection and saline. So doctor does trial and error method to find the vein. In this case patient will suffer from a lot of pain. So this is the main motto of our project to avoid the patient from suffering those pains and doctors can easily find the vein. So in this project we are going to design a contact type vein detector unit which detects the vein on human's skin, also it is used to measure the other parameters such as Blood pressure monitoring, Temperature etc.

IndexTerms— : Internet of things, Arduino module, Led array circuit .(keywords)

I. INTRODUCTION

The main objective of the product is to detect the veins of patient. When the doctors are treating trauma patients, every second counts. Bruises, bums and other physical injuries make it difficult to locate veins and administer life saving drugs or solutions[2]. In such cases it becomes very necessary to have a device that detects the exact location of required vein.[1]. Also in case of blood transfusion, blood donation, blood with draw, etc. it is necessary to know the exact position of the veins. Even trained nurses and doctors many times find it difficult to exactly locate the blood veins, on the first attempt, especially for obese people. In various medical situations, the exact location of veins needs to be identified [4]. In market several products are available for vein detection but most of them are used for only to detect the veins of the patient and cost of that product is also a problem for the practioners But these product is not only useful for the detection of veins but also for the measurement of the parameters such as blood pressure monitoring, temperature measurement etc[3][4].

II. PROBLEMS AND RELATED WORK

In comparison with other parameter—fingerprints, voice, signature the vein model is not completely studied. There are several scientific questions still unanswered regarding hardware and software approaches to the correct feature extraction of vein patterns. There are no known studies on the possible multispectral character of the radiation sources or the influence of chromophores, melanin, or adipose tissues on vein scanning accuracy applications—recognition and not solely verification. On another vein, the low-cost entry point for a makeshift vein hardware scanner has created many opportunities for scientific researchers to implement algorithms and feature extractors. However, the quality of the raw images acquired from these systems is often very low

Product Perspective

This system uses a color property of LED's. LEDs color are and wavelength are varied using microcontroller. This input is given through the intensity adjustment switch. Microcontroller drives the LEDs using LED driver circuit and takes constant current input from Constant current supply section. The complete circuit is powered by 5V regulated DC power supply.

III. HARDWARE INTERFACES

ARDUINO UNO- R3

The Arduino R3 Uno is a microcontroller board based on the ATmega328. It has 14 digital input/output pins (of which 6 can be used as PWM outputs), 6 analog inputs, a 16 MHz crystal oscillator, a USB connection, a power jack, an ICSP header, and a reset button. It contains everything needed to support the microcontroller; simply connect it to a computer with a USB cable or power it with a AC-to-DC adapter or battery to get started.



Fig -1: Arduino uno R3

BLOOD PRESSURE SENSOR

The Blood Pressure Sensor is a non-invasive sensor designed to measure human blood pressure. It measures systolic, diastolic and mean arterial pressure utilizing the oscillometric technique. Pulse rate is also reported. It is having intelligent automatic compression and decompression it is Easy to operate, switching button to start measuring. it Can read single or all measures

TEMPERATURE SENSOR

The LM35 series are precision integrated-circuit temperature devices with an output voltage linearly-proportional to the Centigrade temperature. The LM35 device has an advantage over linear temperature sensors calibrated in Kelvin, as the user is not required to subtract a large constant voltage from the output to obtain convenient Centigrade scaling. The LM35 device does not require any external calibration or trimming to provide typical accuracies of $\pm 1/4^{\circ}\text{C}$ at room temperature and $\pm 3/4^{\circ}\text{C}$ over a full -55°C to 150°C temperature range. Lower cost is assured by trimming and calibration at the wafer level. The low-output impedance, linear output and precise inherent calibration of the LM35 device makes interfacing to readout or control circuitry especially easy. The device is used with single power supplies, or with plus and minus supplies.

LED DRIVER CIRCUIT

The LM3914 is an integrated circuit (IC) designed by National Semiconductor and used to operate displays that visually show the magnitude of an analog signal. One LM3914 can drive up to 10 LEDs, LCDs, or vacuum fluorescent displays on its outputs. The linear scaling of the output thresholds makes the device usable, for example, as a voltmeter. In the basic configuration it provides a ten step scale which is expandable to over 100 segments with other LM3914 ICs in series. This IC was introduced by National Semiconductor in 1980 and is still available as of 2018 from Texas Instruments. Two variant of this part are the LM3915 with 3dB logarithmic scale steps,, and the LM3916 which emulates the scale of a VU-meter.

ESP 8266 node mcu

NodeMCU is an open source IoT platform It includes firmware which runs on the ESP8266 Wi-Fi SoC from Espressif Systems, and hardware which is based on the ESP-12 module The term "NodeMCU" by default refers to the firmware rather than the development kits. The firmware uses the Lua scripting language. It is based on the eLua project, and built on the Espressif Non-OS SDK for ESP8266. It uses many open source projects, such as lua-cjson, and spiffs.

IV. SOFTWARE INTERFACES

ARDUINO SOFTWARE (IDE)

The Arduino Integrated Development Environment - or Arduino Software (IDE) - contains a text editor for writing code, a message area, a text console, a toolbar with buttons for common functions and a series of menus. It connects to the Arduino and Genuino hardware to upload programs and communicate with them. Arduino is an open-source electronics platform based on easy-to-use hardware and software. Arduino boards are able to read inputs - light on a sensor, a finger on a button, or a Twitter message - and turn it into an output - activating a motor, turning on an LED, publishing something online. You can tell your board what to do by sending a set of instructions to the microcontroller on the board. To do so you use the Arduino programming language (based on Wiring), and the Arduino Software (IDE), based on Processing.

Blynk app

Blynk is a Platform with iOS and Android apps to control Arduino, Raspberry Pi and the likes over the Internet. It's a digital dashboard where you can build a graphic interface for your project by simply dragging and dropping widgets. a project, and built on the Espressif Non-OS SDK for ESP8266. It uses many open source projects, such as lua-cjson, and spiffs.

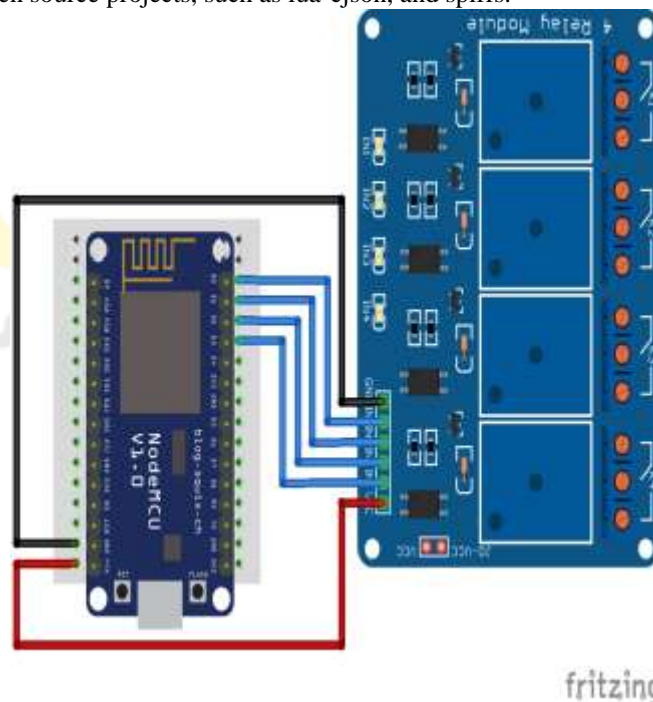

Fig no. 2 Blynk app display

V. PROPOSED SYSTEM DESIGN

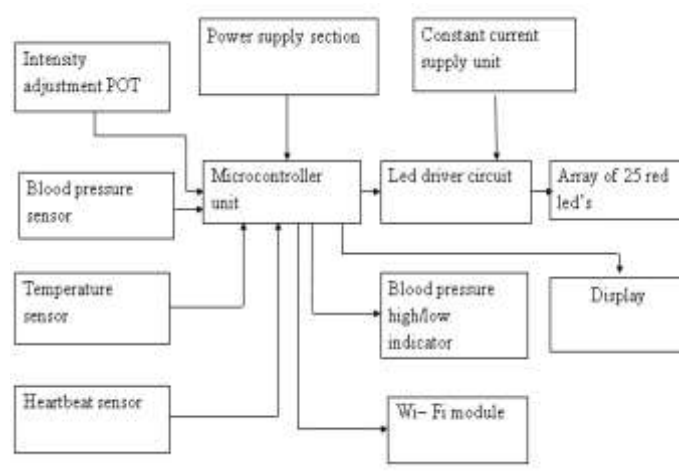

Fig no. 3 Block diagram of the system

This system uses as shown in block diagram microcontroller unit as a main unit. The input is given through the intensity adjustment switch. The input is varied through this switch. The sensors which is selected has taken the output from sensor module. Analog input is taken from the analog pins where as digital input is taken from digital pins of controller. The led array circuit which is used for the indication of veins is taken from the relay drive . Relay 1 and Relay 2 through transistor goes towards the base and the relay is getting on. To the output of relay led array is connected .The supply which is going from constant current source to led is the constant current supply and these supply goes towards R2. The supply of arduino controller and led's array is different. The supply of led is switch through relay and relay's output 1, 2, 3, 4 is connected to the led array.

FLOW CHART

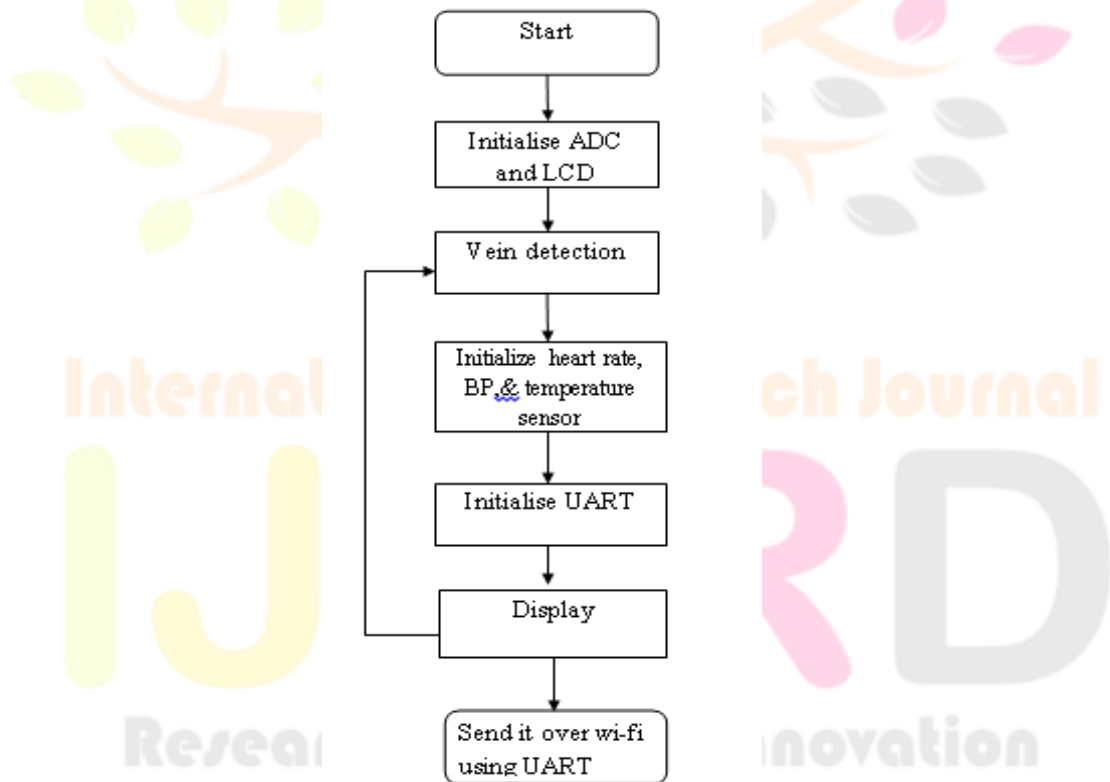

Fig no. 4 flow chart for the system

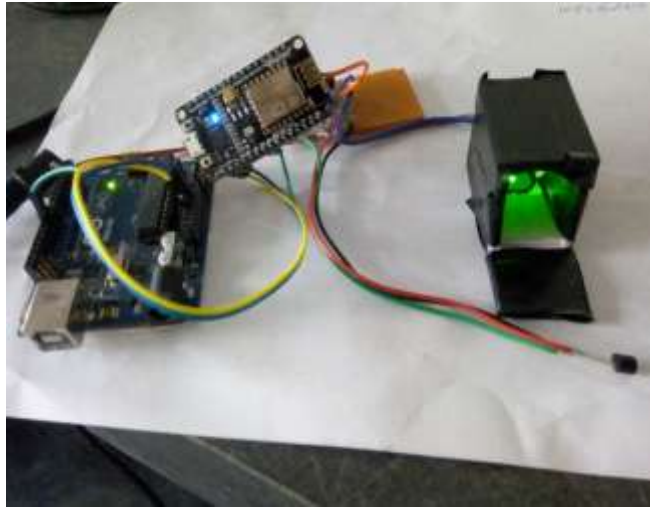

Fig no. 5 vein detection system

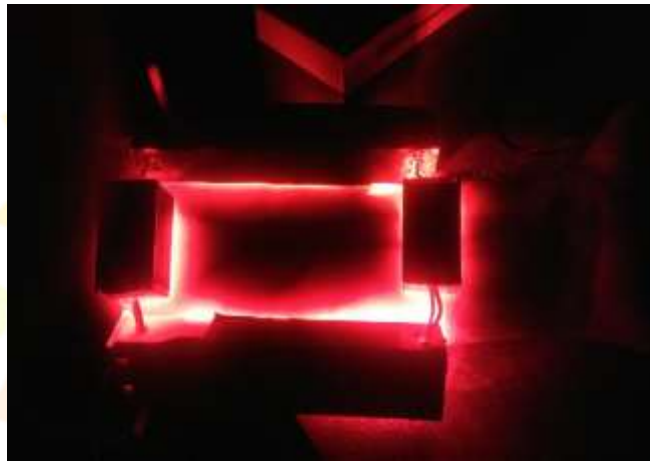

Fig no. 6 output display of vein detection system

VI. CONCLUSION

This system gives it is an extremely low cost and versatile device. It requires no prior specialised training or expertise, and can various applications ranging from intravenous injection or blood drawing assistance, to mapping of surface veins.

The device has several notable advantages over present alternatives. There are a lot of distinct advantages on the described system, mostly in terms of mobility and ease of use. Also, cost effectiveness and simplicity of production can lead to a wide usage. The system, coupled with basic thresholding algorithms, promises to give medically acceptable quality images.

ACKNOWLEDGEMENT

Any accomplishment requires the effort of many people and this work is no different. I find great pleasure in expressing my deep sense of gratitude towards all those who have made it possible for me to complete this project successfully. I would like to thank my guide Mrs. Warsha Kandlikar for her inspiration , guidance and support .I am sincerely thankful to her for providing resources in laboratory and I am very thankful to all teaching and non teaching staff who were directly and indirectly involved in my project work . Lastly, I wish to thank my parents for having raised me in such conductive and loving environment, for teaching me to work hard and persevere which has enabled me to come so far.

REFERENCES

- [1] WangLingyu and Graham Leedham, "Near- and Far- Infrared Imaging for Vein Pattern Biometrics," Proceedings of the IEEEInternational Conference on Video and Signal Based Surveillance(AVSS'06)
- [2] Xiaobin Dai, Ya Zhou, Xiaoming Hu, Meiqing Liu, "A Fast vein display device based on the camera-projector system", Imaging Systems and Techniques (IST), 2013 IEEE International Conference, October 2013, pp.146-149
- [3] P. C. Eng and M. Khalil-Hani, "FPGA-based embedded hand vein biometric authentication system," TENCON 2009 IEEE Region 10 Conference, no. 79900, 2009, pp. 1-5,
- [4] Y. Lei , Z. Gang , R. Si-Heon , L. Choon-Young , L. Sang-Ryong and K.-M. Bae "The platform of image acquisition and processing system based on DSP and FPGA", Proc. Int. Conf. Smart Manuf. Appl.,2008, pp.470 -473