



IOT Based Grid Cut-off of Non-Bill paid Customer

**Prof. Vijay Wadankar¹, Prof. Kanchan Channe², Kamlesh Balpande³, Aman Bhati⁴,
Rashmi Pardeshi⁵, Rina Ramteke⁶**

Electronics & Communication Engineering
Agnihotri College of Engineering, Nagthana, Wardha, Maharashtra.

Abstract: At the present time, along with the development of the Internet, automation becomes a very interesting theme to debate. This paper discusses the development of automation system for residential electricity cut off using network based embedded controller. Nowadays everyone talks about the problem faced by government regarding electricity. Based on this situation, it becomes an extrinsic motivation to develop an automated system for residential electricity device. The system consists of an embedded device to control power supply main switch and update the data into data center. Cut-off warning message is send to users via GSM and short message services. The system helps the electricity provider to reduce the operation cost as the system could cut off electricity automatically when the usage limit is exceeded. In some areas consumers are non-bill paid consumers which intentionally does not pay bill and when the MSEB officials visit to the particular site for disconnecting the supply some consumers try to bypass the connections of the meter and also some consumers try to settle the matter by giving bribes ultimately it regards to electricity power theft. Therefore this project helps the government by gaining the profit by receiving the bill on time.

Key Words: Internet Of things (IOT), Wi-Fi & GSM Module, Superficial

Introduction:- Energy theft is a very common problem in developing countries like India where consumers for energy are increasing consistently as the population increases. Utilities in electricity system are destroying the amount of revenue each year due to energy power theft. It causes shortage of power supply to residential as well as commercial premises. Ultimately it is the country's economy which suffers along with the country's political reputation. Currently as per scenario in India 35-40% people are non-bill paid consumers and 40-45% losses are covered in electricity power theft. The various types of power theft such as direct hooking from line, bypassing the energy meter, injecting foreign element into the energy meter, physical obstruction, ESD Attack.

Direct Hooking from Line: Often power theft is done during transmission by illegal tapping of the power lines to divert the power to the required destinations. It is also done by illegal connections to the power grid stations which are cut at the time of billing.

Bypassing the Energy Meter: In many areas where manual reading of the meter is taken, the person is often bribed to give false readings and thus the amount paid is for the lesser amount of power compared to the power actually consumed. Also meters are tampered by obstructing the motion of disk (usually electro mechanical consist of slowly spinning disks to record the power consumed). In some areas consumers are non-bill paid consumers which intentionally does not pay bill and when the MSEB officials visit to the particular site for disconnecting the supply some consumers try to bypass the connections of the meter and also some consumers try to settle the matter by giving bribes ultimately it regards to electricity power theft. Electric meters can be manipulated, thus causing them to stop, under-register or even bypassing the meter. Consumers, who tamper with electric meter, effectively use power without paying for it. This theft or fraud can be dangerous as well as dishonest. Electric meter security is look upon as major issue in many countries today.

Related Work:

Paraskevagos, developed a sensor monitoring system which used digital transmission for security, fire and medical alarm systems as well as meter reading capabilities for a utilities. This technology was a spin-off of the automatic telephone line identification system, now known as Caller ID.

In 2003, Koay et al, had been successfully designing and implementing Automatic Meter Reading systems using a Bluetooth device, or Bluetooth-Enabled Energy Meter.

Tan et al. had developed a GSM automatic power meter reading (GAPMR) system. The GAPMR System consists of GSM Digital Power Meters installed in every consumer unit and an Electricity eBilling System at the energy provider side. The GSM Digital Power Meter (GPM) is a single phase standard compliance digital kWh power meter with embedded GSM modem which utilizes the GSM network to send its power usage reading using Short Messaging System (SMS) back to the energy provider wireless. At the power

provider side, an eBilling system is used to manage all received SMS meter reading, compute the billing cost, update the database, and to publish billing.

Primicanta et al. propose hybrid Automated Metering Reading (AMR) system which is a combination of ZigBee and GSM technology. In that system ZigBee module is attached to the meter by using interface board and the data collector is connected to the central computer by using GSM. The system is suitable with Malaysian condition which already implemented GSM -based AMR in LPC. With this system TNB can save cost in doing meter reading and provide better services to their customers.

Meanwhile Norozina, A. stated that Tenaga Nasional Berhad was a pioneer in the utilization of ICT as a critical enabler in supporting its business and service delivery. TNB utilizes ICT in supporting its end-to-end business life-cycle inclusive of planning, development, operations and customer services processes. ICT is also extensively utilized in supporting management and administrative processes within TNB in the areas of finance, procurement and human resource management.

Proposed Design: In this paper we proposed a system to improve TNB services efficiency by implementing the automatic cut off system once the customer's power consumptions reach to the limit. The system consists of network embedded devices which are integrated with the main management system in data center. The management system includes billing module, alert module and application module. This system consists of two subsystem; Central provider side and Customer side as shown in Figure 1.

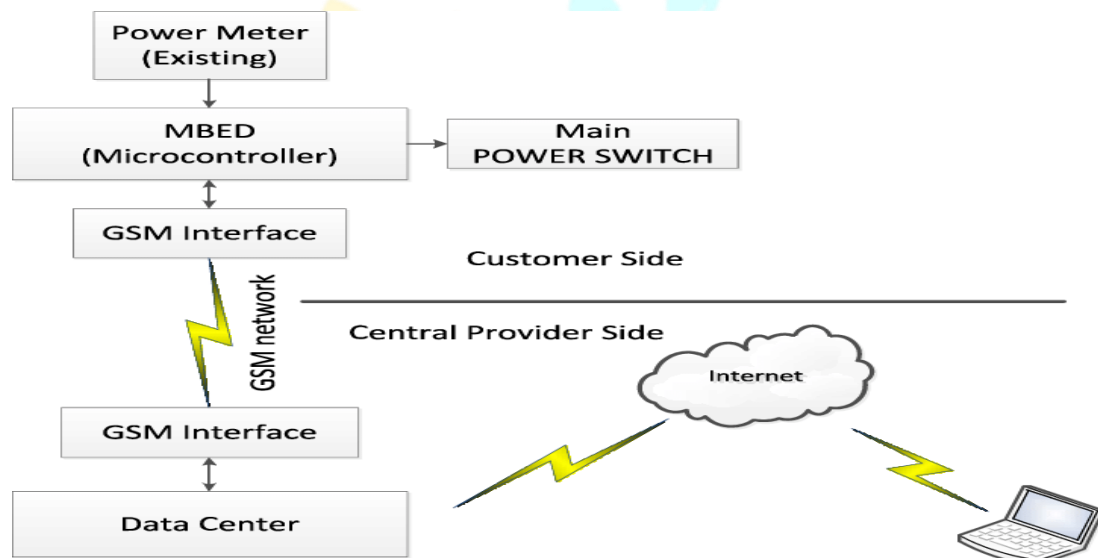

Fig. Automation of Residential Electricity Cut Off Using GSMBased Controller

Meanwhile at customer side, the subsystem, which is the meter reading, is done by a MBED microcontroller. The MBED Microcontrollers are a series of ARM-based microcontroller development boards designed for fast, flexible and low-risk professional rapid prototyping. By summation of the energy meter readings they calculate the Energy Power theft. In order to overcome all the drawbacks of conventional system we are designing "Smart energy controlling system". The system architecture of Smart energy controlling system consists of Wemos ESP8266, c and Relays. The energy consumptions was calculated by MSEB person monthly. And if any consumer not pay the bill then the online system will turn OFF the grid and SMS will send to the consumer. [4]

Circuit Diagram

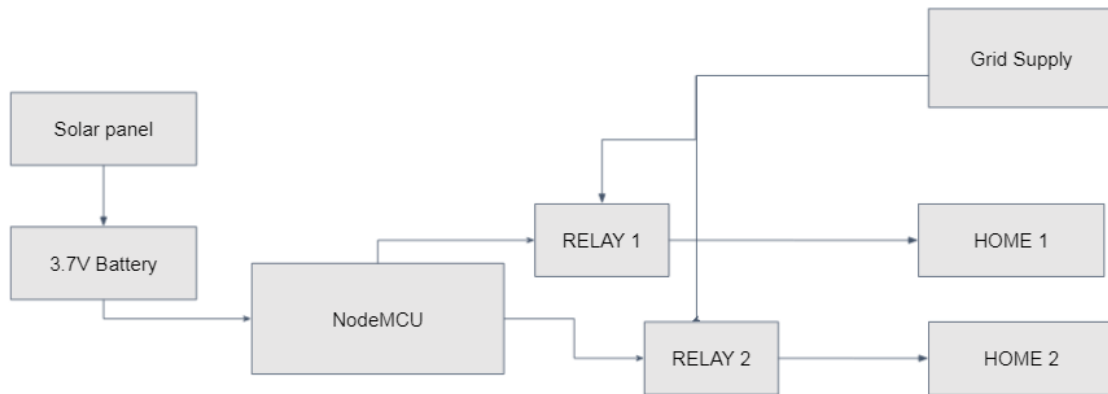
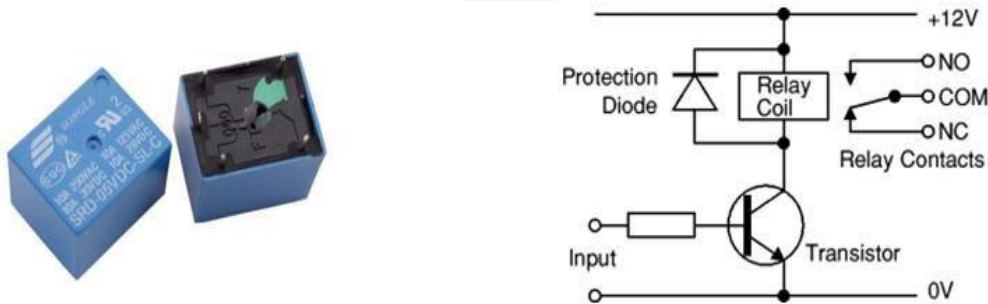

Fig.1.3.3 Circuit diagram of Smart Energy controlling system

The system uses NodeMCU as a wifi enabled microcontroller that connects to relay and relay is connected to the load. The current sensor is used to detect the current through phase and sends a signal to the analog pin of the controller. The system is powered by 3.7V battery that charge from solar panel.

Equipments:

1. Relay (SPDT Relay): A relay is an electrically operated switch. Current flowing through the coil of the relay creates a magnetic field which attracts a lever and changes the switch contacts. The coil current can be on or off so relays have two switch positions and most have double throw (changeover) switch contacts. SPDT relay is used in this system. The Single Pole Double Throw SPDT relay is quite useful in certain applications because of its internal configuration. It has one common terminal and 2 contacts in 2 different configurations: one can be Normally Closed and the other one is opened or it can be Normally Open and the other one closed. So basically you can see the SPDT relay as a way of switching between 2 circuits: when there is no voltage applied to the coil one circuit “receives” current, the other one doesn’t and when the coil gets energized the opposite is happening.



2. WEMOS Microcontroller ESP8266: The board we are using is called “We MOs D1 Mini” and has an ESP8266 module on it, which we will be programming. It comes with the latest version of Micro Python already setup on it, together with all the drivers we are going to use.

The D0, D1, D2, numbers printed on the board are different from what Micro python uses – because originally those boards were made for a different software. Make sure to refer to the image below to determine which pins are which.

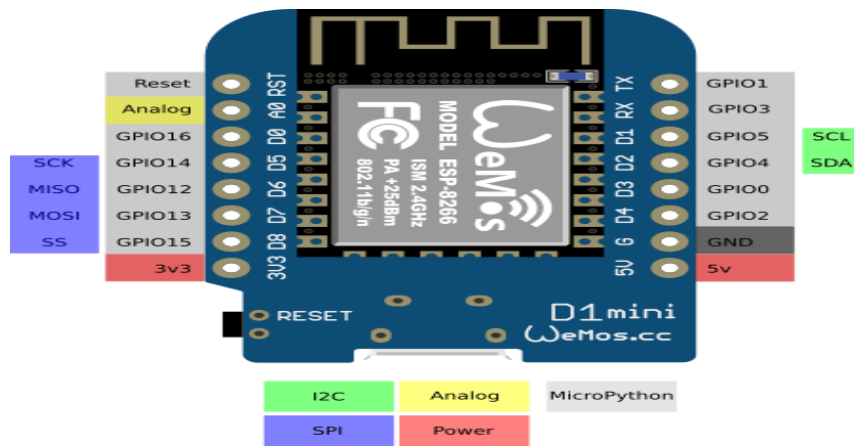

3. GSM SIM 800L:

Mini GSM / GPRS breakout board is based on SIM800L module, supports quad-band GSM/GPRS network, available for GPRS and SMS message data remote transmission.

The board features compact size and low current consumption. With power saving technique, the current consumption is as low as 1mA in sleep mode. It communicates with microcontroller via UART port, supports command including 3GPP TS 27.007, 27.005 and SIMCOM enhanced AT Commands.



OVER-VIEW OF THE PROJECT:

The aim of the project is to design and control a system which will automatically cut-off the electricity connection directly from the electricity pole for those consumers who fail to pay electricity bill on time. When M.S.E.B officials arrive at that particular site to cut-off the supply, some consumers argue with the officials and try to settle the matter by giving bribes. Even if after disconnecting the supply, some consumers may bypass the system and connect the home appliances from the service mains. So to overcome all these issues a prototype is proposed which includes Wemos ESP8266, relays through which it will automatically cut-off the electric supply as per given instruction by microcontroller from the pole itself for that particular consumer who does not pay electricity bill within a specific given period. Also power theft will be taken care by this proposed Smart energy controlling system. A power theft is of various types such as direct hooking from line, bypassing the energy meter, injecting foreign element into the energy meter, physical obstruction, ESD attack on electronic meter. A current sensor which senses a current between the transmission line and energy meter and provides advanced theft monitoring in this system. Hence this system is very useful as it can detect / monitor and overcome all the issues of power theft. The cost of this system is economical without compromising the functionality and accuracy of the system. The cost of the system is economical without compromising the functionality and accuracy of the system.

WORKING:

Conventional system includes the electricity meters which are installed at consumer's premises and the electricity consumption information is collected by meter-readers on their fortnightly or monthly visits to the premises. For a Electricity Power theft existing system had energy meters connect on each phase of line. By summation of the energy meter readings they calculate the Energy Power theft. In order to overcome all the drawbacks of conventional system we are designing " Smart energy controlling system".The system architecture of Smart energy controlling system consists of Wemos ESP8266, c and Relays.[6] The energy consumptions was calculated by MSEB person monthly. And if any consumer not pay the bill then the online system will turn OFF the grid and SMS will send to the consumer Switching power is through the step down transformer. Wemos is wifi for continuous online monitoring. It online monitors the system and also trips the circuit via relay after getting signal command through Wemos. SPDT relay will disconnect and reconnect the supply as per the microcontroller's instruction .When the consumer fails to pay a electricity bill after a given period the wemos will automatically disconnect the supply of that particular consumer through relays and when the consumer pays the electricity bill it will reconnect the supply of that particular consumer. Basically a circuit will be fitted i.e.system in consumers home so from that we will aquire data and after acquiring we will upload/update the data on cloud service so that owner of smart grid (MSEB) and customer can access that data.The system consist of Esp8266 module which is a microcontroller and it controls the whole system.The system is connected in between the Mains Line and the Home incoming supply to the energy meter.In the circuit, we give 230V supply as AC input to meter.Input part and Output part of meter each have one phase and one neutral port this output phase wire connected to load (bulb) through relay.Relay by default is in close condition.Circuit starts working when relay is in close condition.

HARDWARE DESIGN:

Prototype System



System is On

Research Through Innovation



Control Panel for ON/OFF

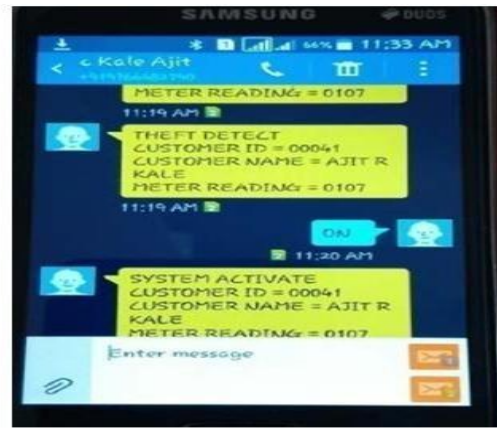

Message to the Customer

Conclusion

The project model reduces the manual manipulation work. Use of Esp8266 in our system provide the numerous advantages of wireless network systems. In this paper we proposed a system to provide early warning to the users of electric power which provided by government. In the present situation all costumers are using manual communication. To reduce the manual efforts and human errors, we need to have some kind of automated system monitoring all the parameters and functioning of connections between the customers and electricity board .Also by implementing this system we can control the usage of electricity on consumer side to avoid wastage of power.

Since there is need to utilize energy in better and efficient way which is beneficial in power sector.

Acknowledgement

Wish to acknowledge Prof. Vijay Wadankar Electronics & communication Department, Agnihotri College of Engineering, Wardha. For her best suggestion and support.

References

- [1] YT Park, P. Sthapit, and JY Pyun, "Smart digitaldoor lock for the automation home ", in Proc. econIEEE Conference, pp 1-6. 2009
- [2] K. Atukorala, D. Wijekoon, M. Tharugasini, I.Perera, and C. Silva, "Smart eye - Integrated solutionto home automation, security and monitoring through mobile phones ". Third International Conference onNext Generation Mobile Applications, Services andTechnologies. Sep. 15-18, pp. 64- 69. 2009.
- [3] M. Merabti, P.Fergus, O. Abualma'atti, H. Yu,and C. Judice, "Managing distributed networkedappliances in home networks", in Proc., Of the IEEE,vol. 96, No. 1, pp. 166-185, 2008.
- [4] S. Ebrahimi-Taghizadeh, A. Helmy, S. Gupta."TCP vs. TCP: to systematic study of adverse impactof short-lived TCP flows on long- lived TCP Flows". University of Southern California, Department ofElectrical Engineering. Los Angeles, USA. 2005.
- [5] M. Todorovic, and N. Lopez-Benitez. "Efficiencystudy of TCP Infrastructure protocols in wirelesnetworks ". Texas Tech University,Department of Computer Science. 2006.
- [6] A. Kuzmanovic, and EW Knightly, "TCP-LP:Low-Priority service via end-point congestioncontrol."IEEE / ACM Transactions on Networking,Vol. 14, No. 4, 2006.
- [7] Y.-T. Li, D. Leith, and RN Shorten."Experimental evaluation of TCP protocols for highspeednetworks."IEEE / ACM Transactions onNetworking, vol. 15, no. 5, pp. 1109- 1122. 2007.
- [8] SC. Tsao, YC. Lai, YD. Lin. "Taxonomy andevaluation of TCP- friendly congestion-monitoringschemes on fairness, aggressiveness, andresponsiveness."Network IEEE, vol 21. No. 5, pp. 6-15.2007.
- [9] S. Henna. "A Throughput analysis of TCP variantsin mobile wirelessNetworks ". Third International Conference on NextGeneration Mobile Applications, Services andTechnologies. Sep. 15-18., Pp. 279-284.