

WIRELESS TECHNOLOGY IN SMART HOME DOOR LOCK

**Dr. R. Senthil Kumar, Associate Professor, EEE,
SNS College of Technology, Coimbatore**

Raj Deepak M EEE, SNS College of Technology, Coimbatore

Vivin Kumar V, EEE, SNS College of Technology, Coimbatore

**Sanjeev P, EEE, SNS
College of Technology, Coimbatore**

This project illustrates an effective low-cost and flexible solution for power management, condition monitoring and energy management in home. The basic operations include remote management and control of domestic devices such as electric lamp; water heater etc., Monitoring of domestic utilizations and providing ambient intelligence to reduce the energy consumption through IoT technology are the key functions of the developed system.

Covering a wide application field, WSNs can play an important role by collecting surrounding context and environment information. However, deploying wireless sensor network (WSNs) configured to access the Internet raises novel challenges, which need to be tackled before taking advantage of the many benefits of such integration. Some of the challenges are security and quality of service management and network configuration. Effective implementation for Internet of Things used for monitoring regular environmental conditional process by means of low cost Omni present sensing unit. The detailed view about the reliable parameter measurement by means of smart sensors is described. The data like temperature, humidity and pressure monitoring will be done with the help of smart sensors.

Electronic devices are getting smaller and more ubiquitous than ever. Currently, thanks to the continuous technological development, these devices can communicate with other devices by means of wireless communication technologies. With the expected massive use of these electronic devices, we are moving towards the Internet of Things (IoT). These "smart" and "connected" devices can communicate using the Internet. Due to this connection, an infinite number of sensors, microcontrollers, actuators, processes, etc. can be monitored and controlled from a smartphone or from a PC.

LITERATURE SURVEY

2.1 ARTICLES REVIEWED

This paper presents an integrated radio and radar system using a single transceiver platform towards millimeter-wave applications. In the proposed system, wireless communication and sensing functions are fully integrated and sequentially arranged in the time domain so that they can operate independently (functional reconfiguration) and also jointly (functional fusion). For this proof-of-principle study, a system prototype is developed in the 24-GHz ISM band using the emerging substrate integrated waveguide (SIW) technology, which has been demonstrated as an attractive low-cost and high-efficiency development scheme for microwave and millimetre-wave systems. Experimental results show a very promising system performance. In addition to high-precision range detection with its radar mode, the present system has proved to have a great capability of wireless radio communication at a data rate of up to 50 Mbps for both binary-phase-shift-keying (BPSK) and quadrature-phase-shift-keying (QPSK) signals.

This paper focuses on the waveform design for a radar-embedded communication (REC) system which can achieve covert communication while improving the spectrum utilization. In order to solve the problem that the conventional embedded communication waveforms are not orthogonal, this paper proposes the orthogonal weighted-combining (OWC) strategy and the orthogonal dominant-projection (ODP) strategy. Furthermore, the OWC strategy can be broken into two strategies: constrained weighted-combining (CWC) strategy and improved weighted-combining (IWC) strategy. Theoretical analysis and

simulation results have shown that these three strategies can dramatically improve communication reliability. Moreover, the performance of the strategies mentioned above has been assessed by the low probability of intercept (LPI) metric. Comparing to the traditional strategies, the IWC strategy shows better LPI performance while the CWC strategy and ODP strategy remain unchanged. Additionally, the ODP strategy can also reduce computational complexity and response delay, which is rather important in the REC system. Any of the three strategies can be selected in accordance with the needs of the application scenario.

2.2 PROBLEM STATEMENT

At these times, all human beings have a place of their own in which they keep their property with the help of locks to limit the penetration of their personal property or privacy, but there are many defects in these locks, such as easy penetration poor security, and the difficulty of dealing with the lock-in one way, which is the traditional key and there is no other way. The second problem is the occurrence of errors on the part of the human being so that the loss of the key is very likely, also carrying many keys that expose them to loss or ease of theft, also you can forget to close the lock, and here the lock cannot be closed by itself because it is mechanical and does not depend on Electromechanical.

CHAPTER SCHEMATICS

3.1 BLOCK DIAGRAM

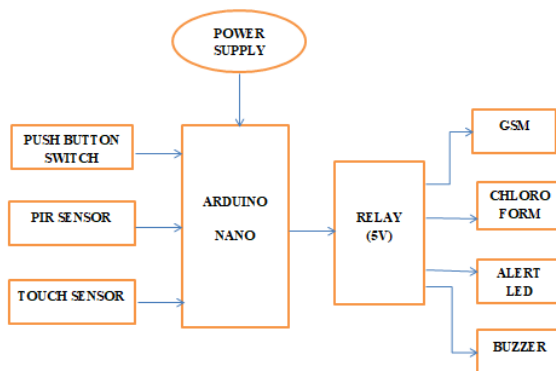

Fig. 3.1 Block diagram

3.2 CIRCUIT DIAGRAM

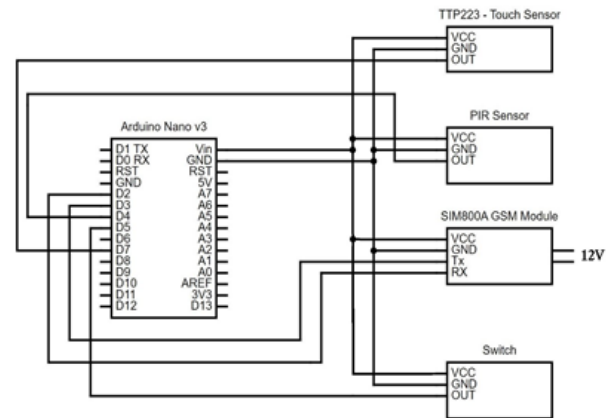

Fig.3.2Circuitdiagram

Touch screen, fingerprint sensor. They are entering into the lock through them and they receive data from the user, then the data is collected and sent to Microcontrollers STM32 and it is processed, and a decision is taken whether to open or not to unlock the lock, wireless control device is sent data from the phone (Control Unit) remotely after that sends it to Microcontrollers STM32 and the data is processed in it. Power supply consists of 8 AA batteries that give 12 V DC power to all design components. Also, for further clarification, all the components are explained separately in the tables.

CHAPTER 4 HARDWARE REQUIREMENTS 4.1 ARDUINO NANO BOARD

Arduino Nano is one type of microcontroller board, and it is designed by Arduino.cc. It can be built with a microcontroller like. At mega 328. This microcontroller is also used in Arduino UNO. It is a small size board and also flexible with a wide variety of applications. Other Arduino board mainly include Arduino Mega, Arduino Pro Mini, Arduino UNO, Arduino YUN, Arduino Lilypad, Arduino Leonardo, and Arduino Due. And other development boards are AVR Development Board, PIC Development Board, Raspberry Pi, Intel Edison, MSP430 Launchpad,

and ESP32 board. This board has many functions and features like an Arduino Due milanove board. However, this Nano board is different in packaging. It doesn't have any DC jack so that the power supply can be given using a small USB port otherwise straightly connected to the pins like VCC & GND. This board can be supplied with 6 to 20volts using a mini USB port on the board. Arduino boards are widely used in robotics, embedded systems, automation, Internet of Things (IoT) and electronics projects. These boards were initially introduced for the students and non-technical users but nowadays Arduino boards are widely used in industrial projects. The Arduino Nano is a small, complete, and breadboard-friendly board based on the ATmega328P released in 2008. It offers the same connectivity and specs of the Arduino Uno board in a smaller form factor. The Arduino Nano is equipped with 30 male I/O headers, in a DIP-30-like configuration, which can be programmed using the Arduino Software integrated development environment (IDE), which is common to all Arduino boards and running both online and offline. The board can be powered through a type-B mini-USB cable or from a 9 V battery.



Fig.4.1 Arduino Nano

4.1.2 ARDUINO NANO PIN OUT

Power Pin (Vin, 3.3V, 5V, GND):

These pins are power pins

- Vin is the input voltage of the board, and it is used when an external power source is used from 7V to

- 5V is the regulated power supply voltage of the Nano board and it is used to give the supply to the board as well as components.

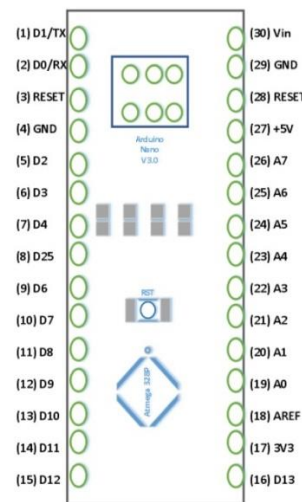

Fig 4.2 Arduino Nano Pin out

- 3.3V is the minimum voltage which is generated from the voltage regulator on the board.
- GND is the ground pin of the board.

RST Pin (Reset):

This pin is used to reset the microcontroller

Analog Pins (A0-A7):

These pins are used to calculate the analog voltage of the board within the range of 0V to 5V

I/O Pins (Digital Pins from D0 – D13):

These pins are used as an i/p otherwise o/p pins. 0V & 5V.

Serial Pins (Tx, Rx):

These pins are used to transmit & receive TTL serial data.

External Interrupts (2, 3):

These pins are used to activate an interrupt.

PWM (3, 5, 6, 9, 11):

These pins are used to provide 8-bit of PWM output.

SPI (10, 11, 12, & 13):

These pins are used for supporting SPI communication.

Inbuilt LED (13):

This pin is used to activate the LED.

IIC (A4, A5):

These pins are used for supporting TWI communication.

AREF:

This pin is used to give reference voltage to the input voltage.

4.1.3 Arduino Nano Communication

The communication of an Arduino Nano board can be done using different sources like using an additional Arduino board, a computer, otherwise using microcontrollers. The microcontroller using in Nano board (ATmega328) offers serial communication (UART TTL). This can be accessible at digital pins like TX, and RX. The Arduino software comprises of a serial monitor to allow easy textual information to transmit and receive from the board. The TX & RX LEDs on the Nano board will blink whenever information is being sent out through the FTDI & USB link in the direction of the computer. The library-like Software Serial allows serial communication on any of the digital pins on the board. The microcontroller also supports SPI & I2C (TWI) communication.

4.1.4 Arduino Nano Programming

The programming of an Arduino Nano can be done using the Arduino software. Click the Tools option and select the Nano board. Microcontroller ATmega328 over the Nano board comes with pre-programmed with a boot loader. This boot loader lets to upload new code without using an exterior hardware programmer. The communication of this can be done with the STK500 protocol. Here the boot loader can also be avoided & the microcontroller program can be done using the header of in-circuit serial programming or ICSP with an Arduino ISP.

4.1.5 Applications of Arduino Nano

These boards are used to build Arduino Nano projects by reading inputs of a sensor, a button, or a finger and gives an output by turning motor or LED ON, or and some of the applications are listed below.

- Samples of electronic systems & products
- Automation
- Several DIY projects
- Control Systems
- Embedded Systems
- Robotics
- Instrumentation

4.2 RELAY MODULE

A 5V relay is an automatic switch that is commonly used in an automatic control circuit and to control a high-current using a low-current signal. The input voltage of the relay signal ranges from 0 to 5V. The relay module with a single channel board is used to manage high voltage, current loads like solenoid valves, motor, AC load & lamps. This module is mainly designed to interface through different microcontrollers like PIC, Arduino, etc.



4.4 Relay

4.2.1 5V Relay Module Pin Configuration

The pin configuration of the 5V relay module is shown below. This module includes 6-pins where each pin and its functionality.



Fig 4.5 5V Relay Module Pin Configuration

Normally Open (NO):

This pin is normally open unless we provide a signal to the relay module's signal pin. So, the common contact pin smashes its link through the NC pin to make a connection through the NO pin.

Common Contact:

This pin is used to connect through the load that we desire to switch by using the module.

Normally Closed (NC):

This NC pin is connected through the COM pin to form a closed circuit. However, this NC connection will break once the relay is switched through providing an active high/low signal toward the signal pin from a microcontroller.

Signal Pin:

The signal pin is mainly used for controlling the relay. This pin works in two cases like active low or otherwise active high. So, in active low case, the relay activates once we provide an active low signal toward the signal pin, whereas, in an active high case, the relay will trigger once we provide a high signal toward the signal pin. However, these modules generally work on an active high signal which will strengthen the relay coil to make contact with the common terminal with the normally open terminal.

5V VCC:

This pin needs 5V DC to work. So 5V DC power supply is provided to this pin.

Ground:

This pin connects the GND terminal of the power supply.

4.2 Relay Module Components

The components in a 5V relay module with a single channel include a relay, output terminal, status LED, power LED, freewheeling diode, input connector & switching transistor.

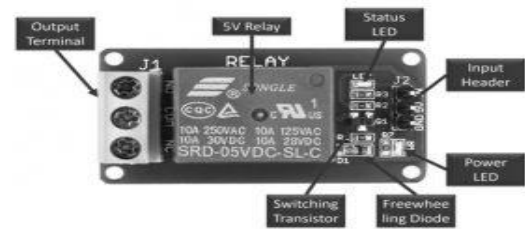

Fig 4.6 5V 1-Channel relay module components

Output Terminal:

The output terminal of the relay module is located at

the left-hand side, used to fix an AC/DC load & AC/DC i/p power source. Every o/p connector's terminal is connected through NC, COM pins & NO of the relay. The relay module consists of screws that are used to connect wires & cables. The max current supported by this module is 10A & the max contact voltage is 250V AC & 30V DC. Thick main cables are mainly used whenever high voltage & current load is used.

Status LED:

Status LED is connected by using a current limiting resistor that is located on the top right side of the relay module. So this LED illustrates the relay status by activating the relay & coil through a signal pin. The DC supplies throughout a relay coil.

Power LED:

Power LED shows the condition of the power source that is connected through the single channel module. If we provide the above 5V source toward both the pins of the module like Vcc & GND, the LED will be damaged due to high voltage.

Freewheeling Diode:

The connection of this diode can be done across the coil to keep away from the back EMF effect, so-called a fly back diode. The type of coil used in the relay is the inductive type. Once the current supplies throughout an inductive load, then it generates a back EMF voltage, which may harm the circuit. So, this diode is mainly used to keep away from this effect.

4.3 TOUCH SENSOR

Touch Sensors are the electronic sensors that can detect touch. They operate as a switch when touched. These sensors are used in lamps, touch screens of the mobile, etc...

Touch sensors offer an intuitive user interface.

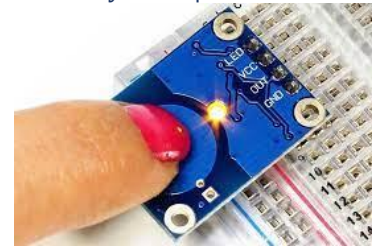

Fig 4.8 Working of touch sensor



Fig 4.7 Touch sensor

Touch sensors are also known as tactile sensors. These are simple to design, low cost and are produced in large scale. With the advance in technology, these sensors are rapidly replacing the mechanical switches. Based on their functions there are two types of touch sensors- Capacitive sensor and Resistive sensor. Capacitive sensors work by measuring capacitance and are seen in portable devices. These are durable, robust and attractive with low cost. Resistive sensors don't depend on any electrical properties for operation. These sensors work by measuring the pressure applied to their surface.

4.3.1 Working

Touch sensors work similar to a switch. When they are subjected to touch, pressure or force they get activated and act as a closed switch. When the pressure or contact is removed they act as an open switch. Capacitive touch sensor contains two parallel conductors with an insulator between them. These conductors plates act as a capacitor with a capacitance value C_0 . When these conductor plates come in contact with our fingers, our finger acts as a conductive object. Due to this, there will be an uncertain increase in the capacitance.

A capacitance measuring circuit continuously measures the capacitance C_0 of the sensor. When this circuit detects a change in capacitance it generates a signal. The resistive touch sensors calculate the pressure applied on the surface to sense the touch. These sensors contain two conductive films coated with indium tin oxide, which is a good conductor of electricity, separated by a very small distance. Across the surface of the films, a constant voltage is applied. When pressure is applied to the top film, it touches the bottom film. This generates a voltage drop which is detected by a controller circuit and signal is generated thereby detecting the touch.

4.3.2 Circuit Diagram of Touch Sensor

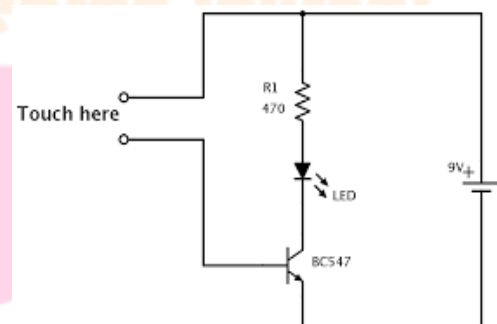

Fig 4.9 Circuit diagram of touch sensor

Touch sensors are also known as tactile sensors. The basic working principle of a touch sensor is that it detects near proximity (also known as touch) without depending on physical contact. In simple words, you can understand that its working is the same as a simple switch or circuit. When any physical medium comes in contact with the touch surface. The internal circuit will be closed inside the sensor and current starts flowing. On the other hand, when this physical contact is broken or released, the circuit will be opened.

4.4 PIR MOTION SENSOR

A Passive Infrared Sensor (PIR sensor) is an electronic sensor that measures infrared (IR) light radiating from objects in its field of view. They are most often used in PIR-based motion detectors. PIR sensors are commonly used in security alarms and automatic lighting applications. PIR sensors detect general movement, but do not give information on who or what moved. For that purpose, an imaging IR sensor is required. PIR sensors are commonly called simply "PIR", or sometimes "PID", for "passive infrared detector".

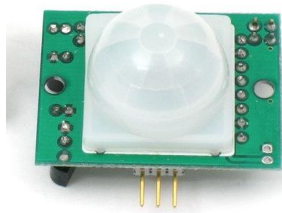

Fig 4.9 PIR Motion sensor

4.5 GSM MODULE

The Global System for Mobile Communications (GSM) is a standard developed by the European Telecommunications Standards Institute (ETSI) to describe the protocols for second-generation (2G) digital cellular networks used by mobile devices such as mobile phones and tablets. GSM is also a trade mark owned by the GSM Association. GSM may also refer to the Full Rate voice code. It was first implemented in Finland in December 1991. By the mid-2010s, it became a global standard for mobile communications achieving over 90% market share, and operating in over 193 countries and territories. 2G networks developed as a replacement for first generation (1G) analog cellular networks. The GSM standard originally described a digital, circuit-switched network optimized for full duplex voice telephony. This expanded over time to include data communications, first by circuit-switched transport, then by packet data transport via General Packet Radio Service (GPRS).



Fig 4.10 GSM Module 900A

4.6 LED LIGHT-EMITTING DIODE

A light-emitting diode (LED) is a semiconductor device that emits light when an electric current flows through it. When current passes through an LED, the electrons recombine with holes emitting light in the process. LEDs allow the current to flow in the forward direction and block the current in the reverse direction.



Fig 4.11 Light Emitting Diode (LED)

LEDs have many advantages over incandescent light sources, including lower power consumption, longer lifetime, improved physical robustness, smaller size, and faster switching.

CHAPTER-5

SOFTWARE DESCRIPTION

ARDUINO

The Arduino Integrated Development Environment (IDE) is a cross-platform application (for Windows, mac OS, Linux) that is written in functions from C and C++. It is used to write and upload programs to Arduino compatible boards, but also, with the help of third-party cores, other vendor development boards. The source code for the IDE is released under the GNU General Public License, version 2. The Arduino IDE supports the languages C and C++ using special rules of code structuring. The Arduino IDE supplies a software library from the Wiring project, which provides many common input and output procedures. User-written code only requires two basic functions, for starting the sketch and the main program loop, that are compiled and linked with a

program stub main into an executable cyclic executive program with the GNU tool chain, also included with the IDE distribution. The Arduino IDE employs the program argued to convert the executable code into a text file in hexadecimal encoding that is loaded into the Arduino board by a loader program in the board's firmware. By default, argued is used as the uploading tool to flash the user code onto official Arduino boards.

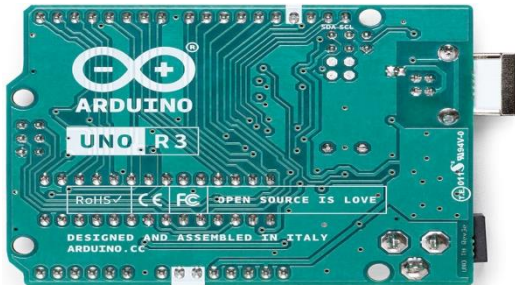

Fig 5.1 Arduino UNO

Arduino IDE is a derivative of the Processing IDE, however as of version 2.0, the Processing IDE will be replaced with the Visual Studio Code-based Eclipse Their IDE framework. With the rising popularity of Arduino as a software platform, other vendors started to implement custom open source compilers and tools (cores) that can build and upload sketches to other microcontrollers that are not supported by Arduino's official line of microcontrollers. In October 2019 the Arduino organization began providing early access to a new Arduino Pro IDE with debugging and other advanced features.

CHAPTER 6

EXPERIMENTAL RESULT

SNAPSHOT OF KIT

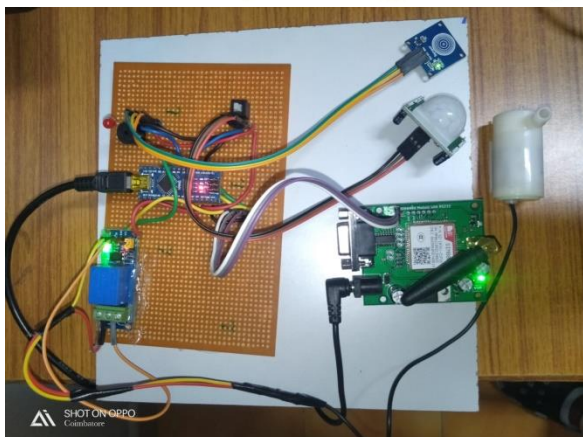

Fig 6.1 Snapshot Kit

CHAPTER 7

CONCLUSION

This Project transfer a normal security lock into higher efficient smart lock. Hence modern logic features such as phone together parent, keypad entry and card system can be incorporated. For higher security a motion sensor is also added. This smart wireless lock tested and formed to be operated in good condition, then protect our property and privacy. This level of smart lock system will be very popular in near future.

REFERENCE

- [1]. M. Rashid, M. W. Anwar, A. M. Khan, "Towards the Tools Selection in Model Based System Engineering for Embedded Systems - A Systematic Literature Review", *Journal of Systems and Software*, vol. 106, pp.150-163, May 2015.
- [2]. M. Rashid, M. W. Anwar, A. M. Khan, "Identification of Trends for Model Based Development of Embedded Systems", *12th IEEE International Symposium on Programming and Systems*, pp. 1-8, Algiers, Algeria, April 2016.
- [3]. M. Imran and M. Rashid, "Architectural Review of Polynomial Bases Finite Field Multipliers Over $GF(2^m)$ ", *2017 IEEE International Conference on Communication, Computing and Digital Systems*, pp. 331-336, Islamabad, Pakistan, March 2017.
- [4]. M. Rashid, M. Imran, A. R. Jafri, "Comparative analysis of flexible cryptographic implementations", *11th International Symposium on Reconfigurable Communication-centric Systems-on-Chip*, pp. 1-6, Tallinn, Estonia, June 2018.