



ANDROID BASED ALCOHOL DETECTION SYSTEM

Pranali Raju Golhar

Author Student, Department of Electronics and Telecommunication, Prof. Dr.Kulkarni Sir Institute of Padmabhooshan Vasantdada Patil, Pune, Maharashtra, India

Abstract -The aim of our paper is to make a system that detects the alcohol level in the body of the driver and avoids accidents due to drink and drive. The system is going to detect whether the driver who is driving a car is drunk or not and accordingly car will be controlled. This can be done using the Internet of Things (IOT). The system is mainly developed and integrated for the road safety of the people. The system traces the breathing levels of the driver and accordingly, actions are taken. We are using an ESP8266 microcontroller, Alcohol detection sensor (MQ3), Internet of Thing (IOT) device, LED, and Buzzer. The system is going to make safety settings inside the cars

Key Words: NodeMCU ESP8266 microcontroller, Alcohol detection sensor (MQ3), Internet of Things (IOT) device, LED, Buzzer

1. INTRODUCTION

“Don’t drink and drive. It’s one test you can’t afford to fail.”

In present time road accidents due to drink and drive is the major problem. Drink and drive is one of the serious public health problem, which in future is likely to be emerged as most significant problem. Between 2008 and 2017, 76,446 people died in 211,405 road accidents nationwide due to consumption of alcohol. Driving under the influence of alcohol has affected and numerous people’s lives are killed. If you drink and drive, you put yourself at risk, and your passengers and pedestrians, and other people, who were on the roads. Just think about that. Every thirty minutes someone’s life is ended and families are devastated. Due to drink drive several lives and properties are in danger. The reason behind this is that the driver of a car is not in a stable position and don’t have control of the car. To overcome this situation, the driver must not be permitted to drive his vehicle. Therefore, drunken driving in almost all countries all over the world is most common reason for accidents.

The ANDROID BASED ALCOHOL DETECTION SYSTEM on a simple principle, if a driver is drunk, the alcohol sensor will detect the level of alcohol in the driver’s breath and if it crosses a set threshold value, an alert will come and the vehicle engine will stop immediately. And message will be

delivered to pre-registered mail with location. This project is designed for the safety of the people seating inside and outside the car.

1.1 OBJECTIVE

Drink drive is taken into account to be the main reason of accidents. Drivers shows a failure in vehicle control under the influence of alcohol. So, to overcome this issue we have proposed a system which will detect alcohol level of driver and lock the engine

2. EXISTING SYSTEM:

In the existing system, the police detect alcohol level by using breathalyzers. The breathalyzer needs the driver to blow into the breathalyzer and indicates the blood alcohol level. According to Section 185 of the Motor Vehicles Act states that an individual driving under the influence of alcohol will be considered guilty if they have alcohol exceeding 30 mg per 100 ml of blood which is detected in a test by a breathalyzer

3. PROPOSED SYSTEM:

In this paper, we are going to introduce ESP8266 microcontroller, Alcohol detection sensor (MQ3), Internet of Thing (IOT) device, LED, Buzzer to provide a safety system for cars and other vehicles as well.

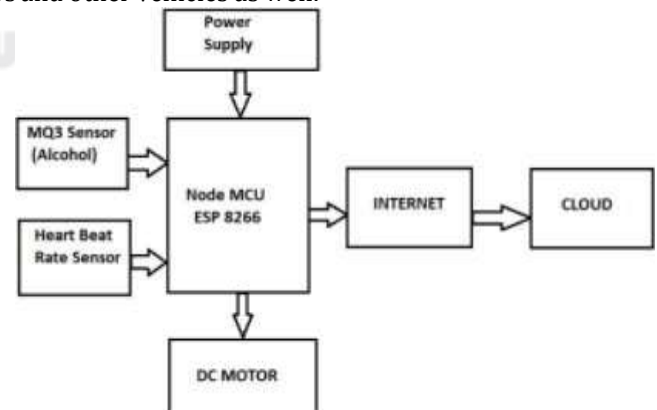

Fig 1: Block diagram

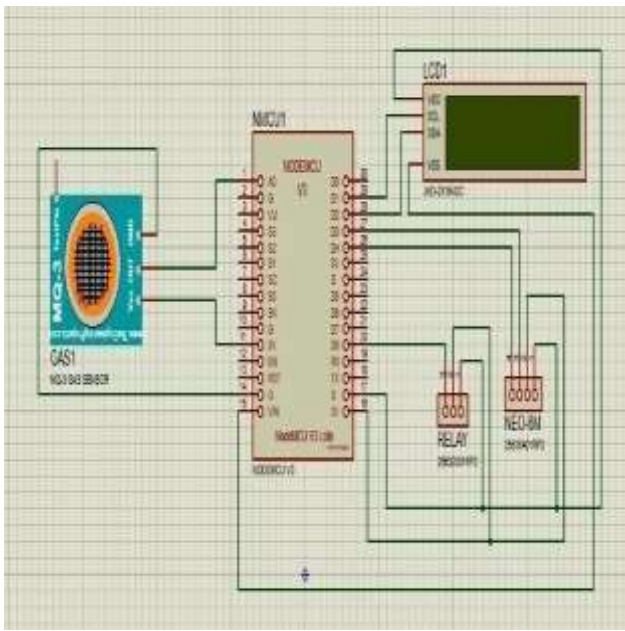

Fig 2: Circuit Diagram of System

4.1 SYSTEM FLOWCHART

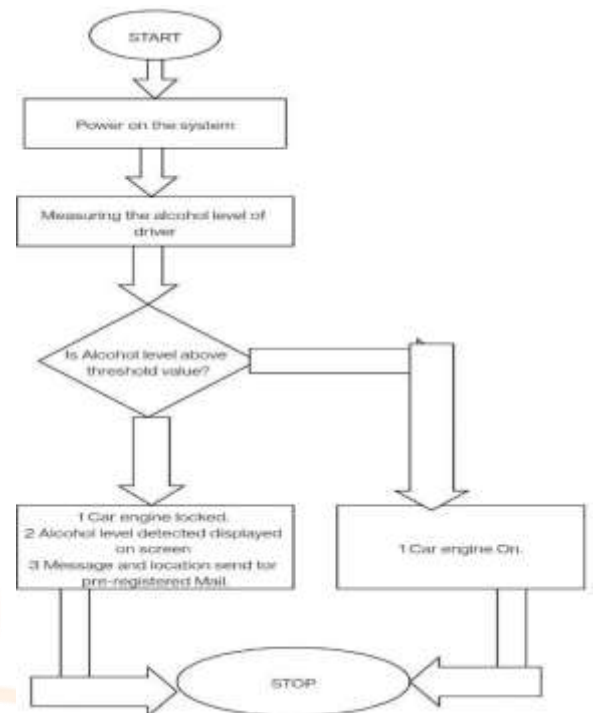

Fig 3: Flowchart of entire system

4.WORKING OF THE SYSTEM

Node MCU ESP8266 is the main part of this system. All the components are connected to Node MCU ESP8266. As soon as power supply is on Alcohol sensor MQ3 will detect the alcohol level of the driver. If level of alcohol is detected then it will send message to Node MCU ESP8266. Node MCU ESP8266 compares the level of alcohol sends by the sensor with normal threshold value of alcohol. If the level of alcohol detected in the sensor is higher than threshold level then Node MCU microcontroller execute the code which will not allow the driver to start the vehicle. If the alcohol level becomes high while car is in moving condition then the car will be slowed down and send mail to owner. Alcohol detection is performed in real-time by the alcohol sensor, the Node MCU ESP8266, and Analog to digital converter circuit. Thus, there is never a time when the system is in off or a sleep state. In ANDROID BASED ALCOHOL DETECTION SYSTEM the system generates an alarm once the level of alcohol measured above a set threshold value. At the same time engine, is locked with the help of deactivating Relay and DC motor. Also, it reads data from the GPS unit which gives the position of the vehicle to the Node MCU ESP8266. Then the Node MCU ESP8266 sends mail with help of IoT. The user can click on the link in the received mail. The integration of the GPS tracker with Google Maps would ensure that the position of the of driver is given out on the maps readily to ensure the easy location and possible further action. And all the data of alcohol level reading, location etc. are stored in cloud.

ACTUAL PICTURES/READINGS

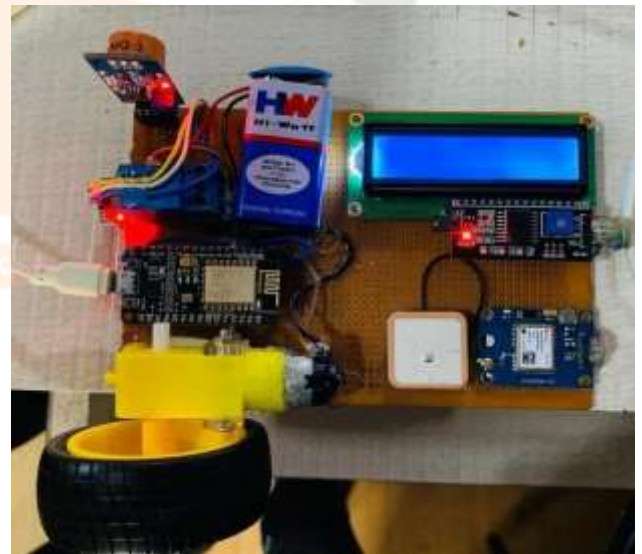

Fig - 5 (a): System Ima

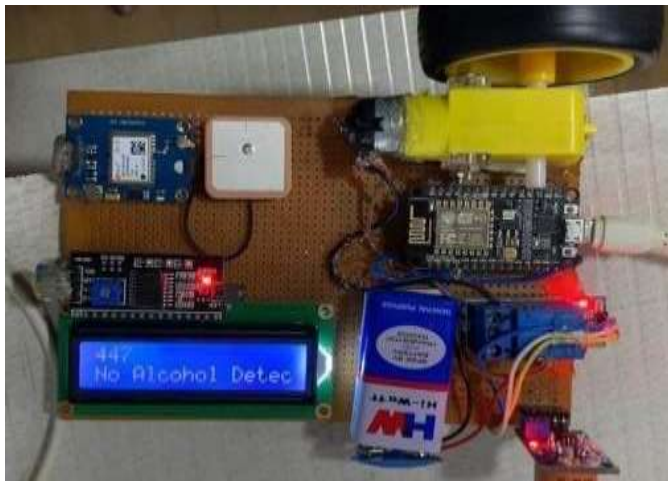

Fig - 5 (b): Once system is on and alcohol is not detected

And display the result on LED screen along with reading. The system measures the value in PPM as shown in Fig - 5 (d).

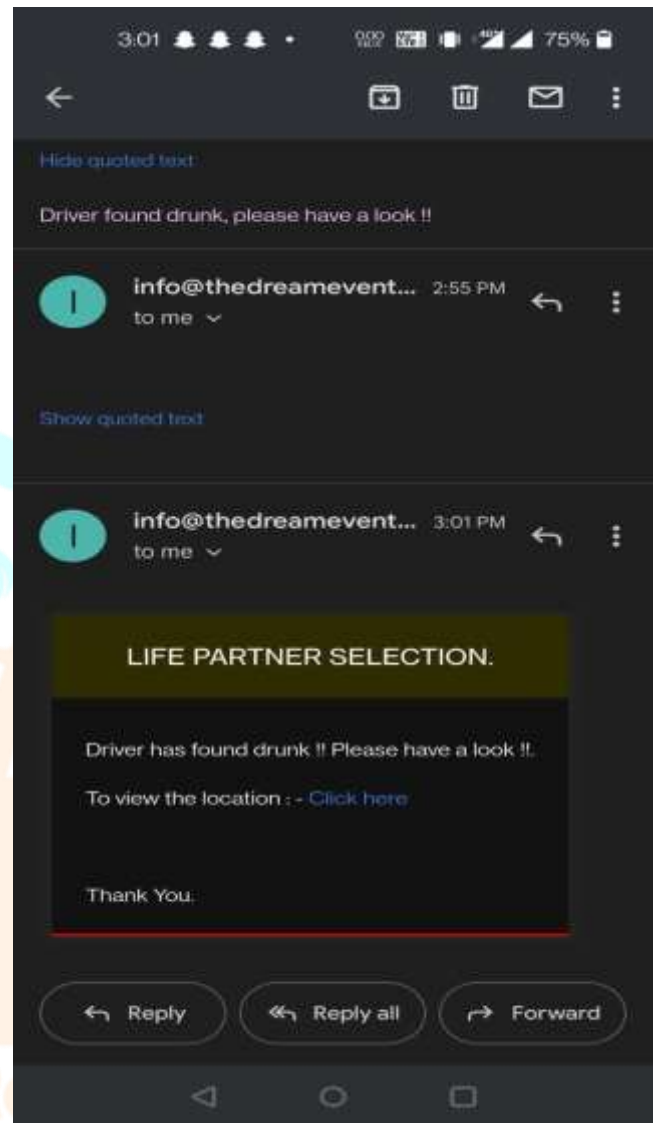

Fig - 5 (e): Notification

The figure shows how the system notifies alerts after measuring the reading of the alcohol level

1. ADVANTAGES

1. The "ANDROID BASED ALCOHOL DETECTION SYSTEM" provides an automatic safety system for cars and other vehicles and helpful for police as well.
2. To prevent accident due to drink and drive.
3. Efficient and Easy to test the alcohol content in the body.
4. Accurate and Quick results.

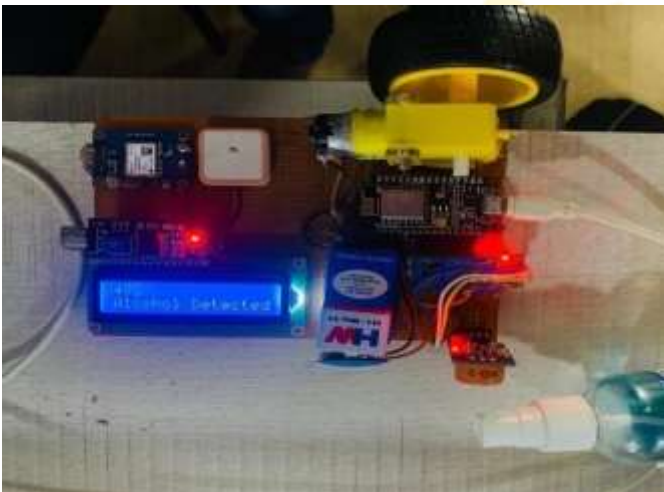

Fig - 5 (c): We used sanitizer to check the working of system as it contains alcohol.

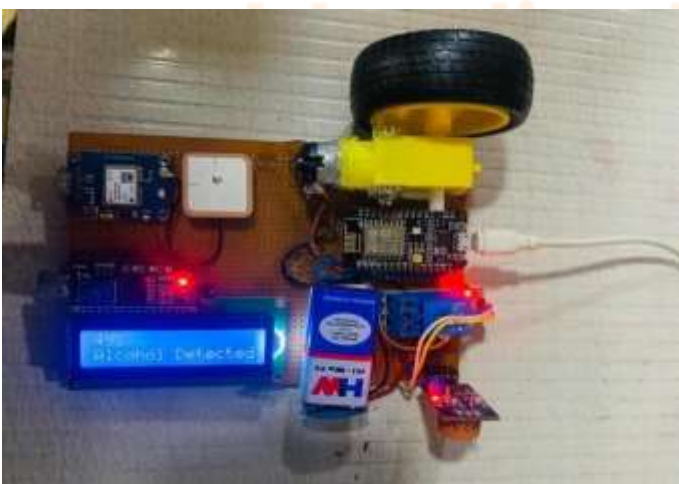

Fig - 5 (d): Alcohol level reading After using sanitizer, it detects the alcohol.

7. APPLICATIONS

1. This system can be used in the various public and private vehicles for detecting whether the driver has consumed alcohol or not.

2. This system can also be used in various companies or organizations or public places like Malls, Gardens, etc. to detect alcohol consumptions of every individual.

8. FUTURE SCOPES

1. In future it can be implemented on two wheelers as well.

2. It can also be used at any place to detect drunken persons.

3. In addition to this we can also add the number of nearest police station to inform police about same.

4. Integrated System detects only the driver's state. This could even be extended by adding an extra alcohol sensor at the traveler seats to discover the presence of alcohol within the vehicle cabin.

9. RESULT

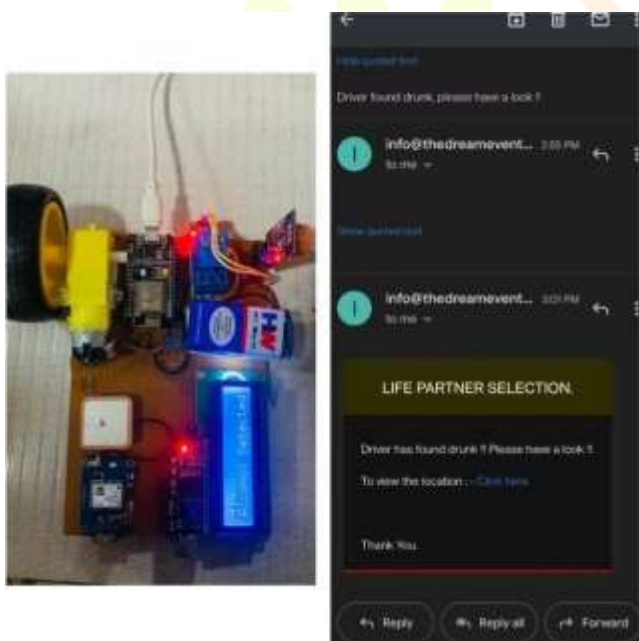

Fig 4: OUTPUT

If alcoholic driver tries command on vehicle the alcohol sensor MQ3 determines the existing of alcohol and shut down the vehicle engine and sound alarm. Peoples in car are aware of situation by the help of "LCD screen" present in the vehicles which will display is driver drunk or not and hence take required action. We can avoid any kind of loss of life by using this system.

This is the final outcome of project. All equipment's are totally tested and connected as required thereby giving us the much-needed result as shown in the image. We implemented the whole process successfully. So, by using this system we can easily identify whether driver is drunk or not. Not every accident of drink and drive can be saved but maximum we can save.

10. CONCLUSIONS

In today's world, the accidents due to drink and drive and rash driving causes a great damage to the lives of people. Even though, the government passes many bills and laws to minimize and control the accidents done under the influence of alcohol. But it is not effective. We have given real time solution to cultivate a smart system for alcohol detection which mainly based on Node MCU ESP8266. This proposed system could minimize and control the accidents which occurs due to drink and drive. The entire system is connected to the vehicles electronic system which will disable the car ignition when it attains the maximum threshold value of alcohol level consumed by the driver. By fitting this system in vehicles, we can safe guard the life of the driver, Passengers as well as people on the roads. The system has long life span. It has very low or negligible maintenance cost and also low power consumption. The sensor readings are updated on the cloud from time to time using IoT. Even if the driver tries to escape after committing the accident, the readings in the cloud will act as major evidence for the police. Government should test and enforce the law to install such circuit in every vehicle and should regulate all companies to preinstall circuit while manufacturing the vehicles. If this is achieved the death rate due to drink and drive will be maximize and the road safety will be more.

ACKNOWLEDGEMENT

This project would not have been possible without the support of our Guide, Dr. N.P. Dhole, has guided us through every step. We are grateful for the opportunity she has provided us.

I'd also like to express my gratitude to a faculty member from the Electronics and Telecommunication department, whose invaluable knowledge and competence assisted us in dealing with a difficult issue

REFERENCES

- [1] "ALCOHOL DETECTION USING SMART HELMET SYSTEM" International Journal of Emerging Technology in Computer Science & Electronics (IJETCSE) ISSN: 0976-1353 Volume 8 Issue 1 –APRIL 201
- [2] M.H. Mohamad , Mohd AminBin Hasanuddin, Mohd Hafizzie Bin Ramli "Vehicle Accident Prevention System Embedded with Alcohol Detector", IJRECE, Volume 1- Issue 4 October

- [3] Gupta, Abhishek, Shriram Ojha, Vikash Kumar, Vikrant Singh, Vipin Malav, and Ramnagariya Gramothan."Alcohol Detection with Vehicle Controlling." International Journal of Engineering and Management Research 6 (2016).
- [4] Keerthana K, Ramya G DRUNK DRIVING DETECTION USING CARIGNITION LOCKING 2018 International Journal of Pure and Applied Mathematics.
- [5] Tejaswini Patil, Aliya Tabassum AUTOMATIC ENGINE LOCKING SYSTEM ALCOHOL DETECTION FOR DRUNK & DRIVE WITH GSM National Conference on Advances in Engineering and Applied Science.
- [6] Muthulakshmi.M, Santhiya.K, Prof.Dhivya.P- SMART HELMET SYSTEM USING ALCOHOL DETECTION FOR VEHICLE PROTECTION, IJIRTSE,ISSN: 2395-5619, Volume - 2.
- [7] Prof. Kulkarni P.H, Ms. Ravina Wafgaonkar, Mr. Gaurav Ahirrao ALCOHOL DETECTION AND AUTOMATIC DRUNK AND DRIVE AVOIDING SYSTEM International Journal of Engineering Research and Applications April 2014.
- [8] "Embedded Controller For vehicle Obstacle Detection and Cabin Alert System" .pdf
- [9] "Accident Prevention using eye-blinking and head movement" ,ETCSIT2012,IJCA

