



# DESIGN OF OPTIMUM STAGES FOR MODULAR MULTI LEVEL CONVERTER

<sup>1</sup>ADDALA MANIKRANTH,

SENIOR LECTURER,

DEPARTMENT OF EEE

SIR C R REDDY POLYTECHNIC,  
ELURU, ANDHRAPRADESH, INDIA

<sup>2</sup>KAJA RAMA KISHORE

LECTURER

DEPARTMENT OF EEE

SIR C R REDDY POLYTECHNIC,  
ELURU, ANDHRAPRADESH, INDIA

## ABSTRACT

MMCs have become one of the best choices for electric vehicles (EV) and storage based electric vehicles as these converters have the ability of conduction in both the directions with bidirectional switches. One of the major issues of concern of an EV is that the storage of energy, as these vehicles battery storage with large capacity and these batteries required to be charged continuously. This feature of EV makes usage of MMCs as an attractive solution. The output available across a MMC is stepped sine wave. Modular multi level converters (MMC) are gaining importance day by day due to their inherent advantages of bidirectional capability, reduced switching loss. As the number of steps increases nearness of output voltage with a sine wave is increased, but this is not true. The authors feel that it is not true in case of a Sinusoidal Pulse Width Modulated Inverter. As the number of levels are increased the Total Harmonic Distortion (THD) in a voltage waveform decreases to a minimum value and then increases. MMC configuration proposed in [1] taken into consideration and simulation studies are conducted using Sinusoidal Pulse Width Modulation control scheme with the help of MATLAB / SIMULINK. The THD levels in the phase voltages and load currents are presented. With the help of simulation studies the optimum number of an inverter are identified.

**Keywords** - Bidirectional Switches, Electric vehicles (EV), Modular multi level converters (MMC), Total Harmonic Distortion (THD)

## I. INTRODUCTION

Power electronic inverters are widely used in industrial power conversion systems both for utility and drives applications (Tolbert and Peng 1998, 1999, 2002). As the power level increases, the voltage level also increases accordingly to obtain satisfactory efficiency. Multilevel Inverters have been attracting attention in recent years due to high power quality, high voltage capability, low switching losses and low Electro Magnetic Interference (EMI) concerns; and have been proposed as the best choice in several medium and high voltage applications such as static VAR compensators and large electrical drives (Min 1999 and Peng 1996, 1997, 2001). Conventional inverter can switch to each input / output connection between two possible voltage (and possible current) levels. Multilevel inverter can switch their outputs between many voltage or current levels and have multiple voltage or current sources (or simply capacitors or inductors) as part of their structure. A multilevel inverter can be implemented in different topology with its own advantages and limitations. The simplest technique adopted is parallel or series connection of conventional inverters to form the multilevel inverter. More complex structures involve, inserting inverter within inverter to form a multilevel inverter. Whatever approach

is chosen, the subsequent voltage or current rating of the multilevel inverter becomes a multiple of the individual switches and so that the power rating of the inverter can exceed the limit imposed by the individual switching devices. Pulse Width Modulation (PWM) of multilevel inverter is typically an extension of two level inverters. The most common types of multilevel voltage source pulse width modulation are sine triangle modulation and space vector modulation (Bowes 1975 Bhagwat and Stefanovic 1983). Multilevel sine triangle modulation relies on defining a number of triangle waveforms and switching rules for the intersection of these waveforms with a commanded voltage waveform. This method is fairly straightforward and insightful for the description of multilevel systems.

Multisource multilevel inverter can increase the level with same number of DC sources with different values. The topologies are cascaded, hybrid and new hybrid H-bridge multilevel inverter. The topology was achieved by connecting the H-bridge inverter in series with other H-bridge inverter. The topology is a series connected H-bridge inverter which is also known as a cascaded H-bridge inverter. It was developed by Baker and Bannister in 1975.

The interest in the multilevel inverter except three level inverters faded during the 1980s, but in the 1990s this technology began to draw more attention again. For example Marchesoni et al (1990) proposed a cascaded multilevel inverter which could be used in nuclear fusion experiments. Moreover, Marchesoni and his research group made a significant contribution to the multilevel inverter research, especially in control and modulation, in the early 1990s; (Marchesoni 1998, Marchesoni and Tenca 2002, Marchesoni et al 1990, Carrara et al 1990, Fracchia et al 1992).

During 1990 to 2000s, several other variations of multilevel inverter topologies have been proposed. Several alternative ways to implement a cascaded inverter were introduced by Stemmler and Guggenbach (1993), Kawabata et al (1996), Corzine et al (1999), Barcenas et al (2002), Soto et al (2003). One of the proposed cascaded inverter topologies includes a machine with open end windings and a two level inverter, which is connected to one end of the windings and the H-bridge to the other side (Kang et al 2000). Another interesting topology that has attracted increasing attention is the modular multilevel inverter (Lesnicar and Marquardt (2003), Glinka and Marquardt (2003, 2005), Hagiwara and Akagi (2008), Rohner et al (2009), Antonopoulos et al (2009)).

In this Paper a MMC configuration is taken for analysis. The MMC configurations that produce 3,5,7,9,11,13,15,17,19,21,23,25,37 are modeled and simulated using MATLAB / SIMULINK. Phase disposition carrier based sinusoidal pulse width modulation is applied for control of switches of the converter. In section II describes control of MMC Converter. In sections III modeling aspects of MMC for production of 23 levels in output is presented. Carrier signals that are produced for control of 25 level MMC, Comparison of Total harmonic distortion of MMCs producing different levels in their output voltages are presented in Section IV, Results and conclusion are given in section V.

**II. CONTROL OF MMC CONVERTER**

One of the most commonly used voltage balance configurations for energy transfer is shown in Figure 2.1. An inductor is connected between the cells of a Half – Bridge arm. These circuits require  $2n - 2$  switching devices and  $n-1$  inductances for a  $n$  cell configuration. An additional inverter circuit is also required for driving the motor and requires a charger circuit for battery charging purpose.

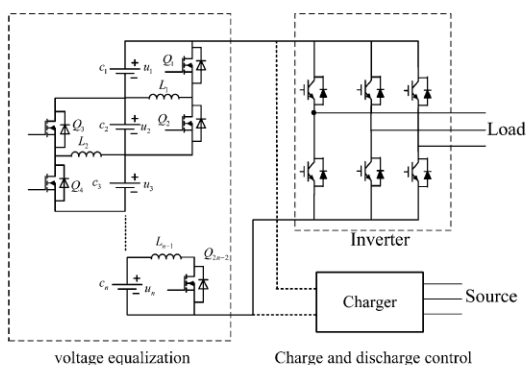
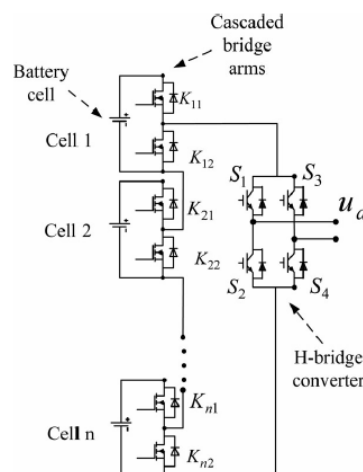

**Figure 2.1:** Traditional Power Storage with voltage equalization circuit and inverter.

The output terminals of inverter are connected to the load terminals as well as charger circuit. When the battery cells

are connected to the charger terminals, the load is bypassed and vice –versa.

Hybrid cascaded MMC proposed in [1] is taken for analysis. The circuit is divided into two parts one part contains cascaded half – bridges with battery cells and a H-Bridge converter. The output voltage of cascaded half bridges is a stair cased half sinusoidal wave with frequency equal to  $2*f$ , Where  $f$  is the output voltage frequency. H – Bridge connected here is used for polarity reversal of the voltages produced by the cascaded half – bridges. The advantage of this configuration is that each cascaded half – bridge cell has the ability of involving the battery cell into the voltage producing and by passed mode. This gives flexibility in changing the number of cell to be connected in voltage production mode. As a result a variable voltage will get resulted across the output terminals of the load. The switches used in H- Bridge are operated at higher frequency than those used in cascaded half – bridges, and equal to  $f$ . At the output terminals of H-Bridge  $2*n-1$  levels of ac voltage is available. Where  $n$  is the number of cascaded half - bridges in each phase. As the number of cascaded cells increased, increased numbers of output levels are available across the terminals of H – Bridge inverter. This makes the output voltage closer to an ideal sine wave and results reduced content of  $\frac{dv}{dt}$  harmonics.



**Figure 2.2:** Hybrid Multi level inverter proposed in [1].

For a cascaded half – bridge converter the switching state is defined as follows

$$S_x = \begin{cases} 1 & \text{Upper Switch is ON} \\ 0 & \text{Upper Switch is OFF} \end{cases}$$

The Upper and Lower switches are operated in a complementary manner.

**III. MODELING OF 23 LEVEL HYBRID CONVERTER**

Cascaded Half – Bridge based Modular Multi level converter is shown in figure 3.1. 11 Levels in output voltage are available across its output terminals. As a result 23 Levels are available across the H-Bridge inverter. Simulation model of 3-Phase 23 level hybrid converter is presented in Figure 3.2. Carrier signals for control of the switches S11, S21,..... S111 are given in Figure 3.3. Switching pattern for obtaining 12 levels across half – bridge based converter are presented in Table 3.1.

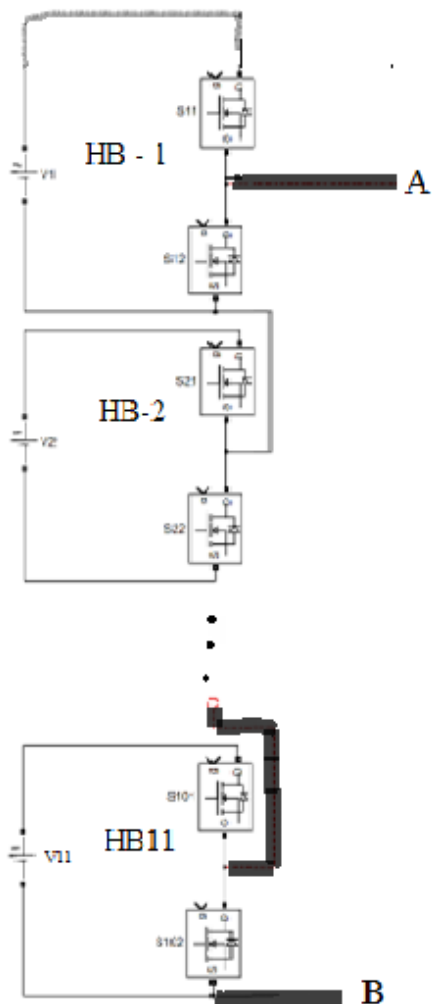

Figure 3.1: Cascaded half – Bridge based MMC for production of 11 Levels at its output terminals.

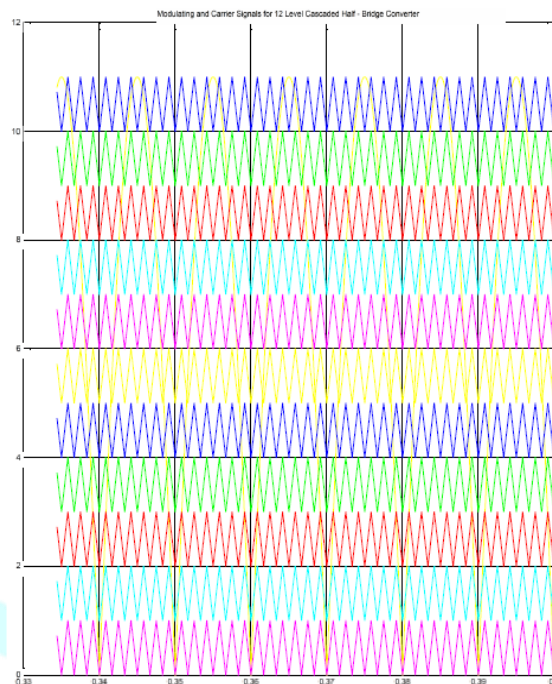

Figure 3.3: Modulating and carrier Signals used for Generation of Switching pulses for Switches used in Cascaded Half – Bridge Converter.

S.	S11	S21	S31		S101	S111	Out
1	0	0	0	. .	0	1	V1
2	0	0	0	. .	1	1	2V1
3	0	0	0	. .	1	1	3V1
4	0	0	0	. .	1	1	4V1
5	0	0	0	. .	1	1	5V1
6	0	0	0	. .	1	1	6V1
7	0	0	0	. .	1	1	7V1
8	0	0	0	. .	1	1	8V1
9	0	0	1	. .	1	1	9V1
10	0	1	1	. .	1	1	10V1
11	1	1	1	. .	1	1	11V1

Table 3.1: Magnitude of output voltage with respect to Switching states of switches

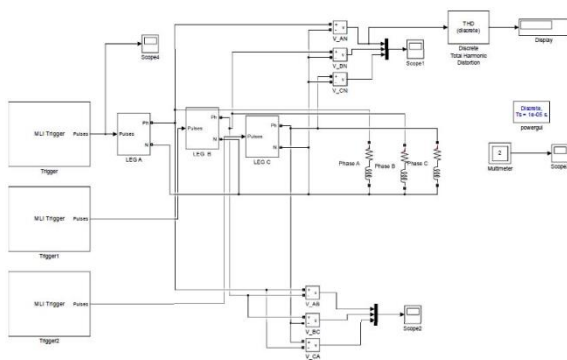

Figure 3.2: Simulation model of 3 – Phase 23 Level Cascaded Hybrid Inverter.

#### IV. SIMULATION RESULTS

Simulation studies are conducted for the model derived to obtain different voltage levels of a cascaded half – Bridge based MMC Inverter. Total harmonic distortions in load voltage are evaluated and are tabulated in table 4.1 for the converter when supplying RL load with 10Ω and 110mH inductance. Battery cells are considered as ideal voltage sources and are modeled as constant DC voltage sources. Amplitude of Battery voltage is taken as 12V. The Switches of H-Bridge inverter is controlled with pulses of 50Hz frequency with duty ratio equal to 0.5. The voltage across the load with load current for Phase A of a 3 – Phase Hybrid Converter is presented in Figure 4.1. Input applied to H-Bridge inverter is given in Figure 4.2. Load Current and Load Voltages of Phase A are presented in Figure 4.3. A carrier frequency of 25000Hz is taken for generation of switching pattern for the switches used in half – bridges and MOSFETs are used for achieving the switching purposes.

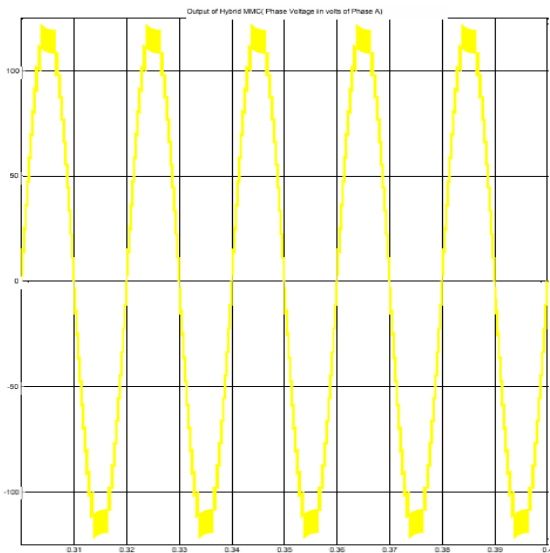

Figure 4.1: Phase Voltage of Phase A in Volts of Hybrid MMC.

Table 4.1: Evaluation of THD's from Simulation Studies.

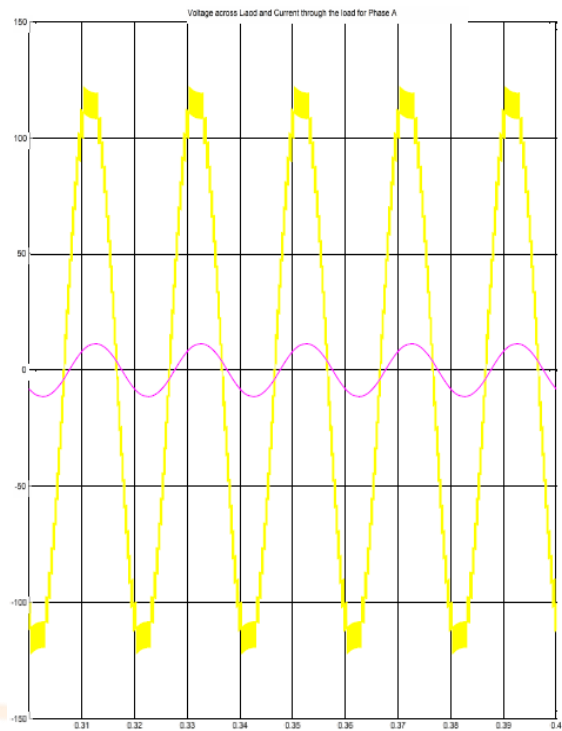

Figure 4.3: Phase Voltage and Currents of Load connected on Phase A of a 3 Phase

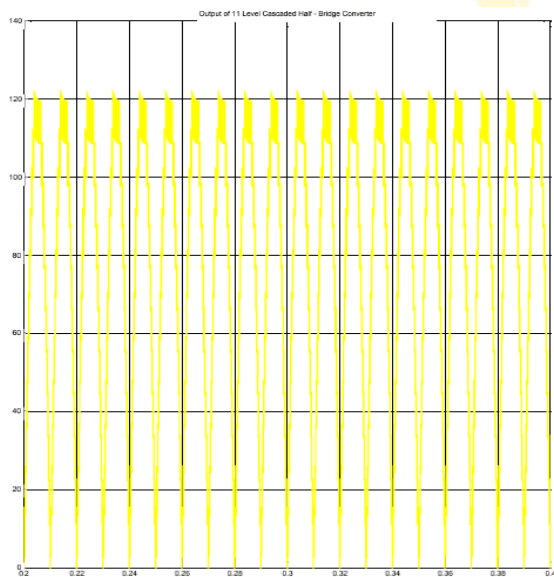

Figure 4.2: Input voltage applied to H – bridge Inverter.

Total Harmonic distortion Analysis is done for the different output levels produced by the converter are presented in table 4.1.

S. No	Peak Amplitude of Voltage in Volts	Levels in Output Voltage	% THD	Change in THD
1	10.37	3	21.00	
2	22.54	5	9.94	11.06
3	34.31	7	6.38	3.56
4	45.78	9	4.75	1.63
5	57.06	11	3.55	1.20
6	68.16	13	2.82	0.73
7	79.13	15	3.06	-0.24
8	89.83	17	2.23	0.83
9	100.4	19	2.16	0.07
10	110.8	21	2.13	0.03
11	121.1	23	2.21	-0.08

### V. CONCLUSION

From the simulation studies conducted on Hybrid MMC it has been found that the levels in output voltage increases and the high power switches are switched at low frequency as a result the switching loss decreases. The MMC converter has the ability of producing the required number of levels in the output voltage; this makes it suitable for variable voltage applications. The Converter offers a reasonably good THD in the load voltages as results the cost of filters will get reduced. As the number of levels increases beyond 19 there in no considerable change in THD values measured for different levels. So it is better to restrict the number of levels to a vale between 17 or 23 for which the THD value is lies between 2.13 and 2.16. Depending upon the load power requirements the numbers of levels required in output are opted. For example for low power applications 17 levels in output may chosen for high power applications 23 levels may be opted.

### REFERENCES

- [1]. Zedong Zheng, Kui Wang, Lie Xu, Yongdong Li, “A Hybrid Cascaded Multilevel Converter for Battery Energy Management Applied in Electric Vehicles”, *IEEE TRANSACTIONS ON POWER ELECTRONICS*, vol. 29, no. 7, pp. 3537 – 3546, July 2014
- [2]. S. M. Lukic, J. Cao, R. C. Bansal, F. Rodriguez, and A. Emadi, “Energy storage systems for automotive applications,” *IEEE Trans. Ind. Electron.*, vol. 55, no. 6, pp. 2258–2267, Jul. 2008.
- [3]. H. M. Zhang and S. P. Ding, “Application of synergic electric power supply in HEV,” in *Proc. 8th World Congr. Intelligent Control Autom.*, 2010, pp. 4097–4100.
- [4]. A. Emadi, Y. J. Lee, and K. Rajashekara, “Power electronics and motor drives in electric, hybrid electric,

- and plug-in hybrid electric vehicles,” *IEEE Trans. Ind. Electron.*, vol. 55, no. 6, pp. 2237–2245, Jun. 2008.
- [5]. K. Jonghoon, S. Jongwon, C. Changyoon, and B. H. Cho, “Stable configuration of a Li-Ion series battery pack based on a screening process for improved voltage/SOC balancing,” *IEEE Trans. Power Electron.*, vol. 27, no. 1, pp. 411–424, Jan. 2012.
- [6]. L. Yuang-Shung, T. Cheng-En, K. Yi-Pin, and C. Ming-Wang, “Charge equalization using quasi-resonant converters in battery string for medical power operated vehicle application,” in *Proc. Int. Power Electron. Conf.*, 2010, pp. 2722–2728.
- [7]. Y. C. Hsieh, C. S. Moo, and W. Y. Ou-Yang, “A bi-directional charge equalization circuit for series-connected batteries,” in *Proc. IEEE Power Electron. Drives Syst.*, 2005, pp. 1578–1583.
- [8]. S. Yarlalagadda, T. T. Hartley, and I. Husain, “A battery management system using an active charge equalization technique based on a DC/DC converter topology,” in *Proc. Energy Convers. Congr. Expo.*, 2011, pp. 1188–1195.
- [9]. K. Chol-Ho, K. Young-Do, and M. Gun-Woo, “Individual cell voltage equalizer using selective two current paths for series connected Li-ion battery strings,” in *Proc. Energy Convers. Congr. Expo.*, 2009, pp. 1812–1817.
- [10]. H. Shen, W. Zhu, and W. Chen, “Charge equalization using multiple winding magnetic model for lithium-ion battery string,” in *Proc. Asia-Pacific Power Energy Eng. Conf.*, 2010, pp. 1–4.
- [11]. P. Sang-Hyun, P. Ki-Bum, K. Hyoung-Suk, M. Gun-Woo, and Y. Myung-Joong, “Single-magnetic cell-to-cell charge equalization converter with reduced number of transformer windings,” *IEEE Trans. Power Electron.*, vol. 27, no. 6, pp. 2900–2911, Jun. 2012.
- [12]. K. Chol-Ho, K. Moon-Young, P. Hong-Sun, and M. Gun-Woo, “A modularized two-stage charge equalizer with cell selection switches for series-connected lithium-ion battery string in an HEV,” *IEEE Trans. Power Electron.*, vol. 27, no. 8, pp. 3764–3774, Aug. 2012.
- [13]. K. Chol-Ho, K. Moon-Young, and M. Gun-Woo, “A modularized charge equalizer using a battery monitoring IC for series-connected Li-Ion battery strings in electric vehicles,” *IEEE Trans. Power Electron.*, vol. 28, no. 8, pp. 3779–3787, Aug. 2013.
- [14]. Y. Ye, K. W. E. Cheng, and Y. P. B. Yeung, “Zero-current switching switched-capacitor zero-voltage-gap automatic equalization system for series battery string,” *IEEE Trans. Power Electron.*, vol. 27, no. 7, pp. 3234–3242, Jul. 2012.
- [15]. L. M. Tolbert, Z. P. Fang, and T. G. Habetler, “Multilevel converters for large electric drives,” *IEEE Trans. Ind. Appl.*, vol. 35, no. 1, pp. 36–44, Jan. 1999.
- [16]. J. Rodriguez, S. Bernet, B. Wu, J. O. Pontt, and S. Kouro, “Multi-level voltage-source-converter topologies for industrial medium-voltage drives,” *IEEE Trans. Ind. Electron.*, vol. 54, no. 6, pp. 2930–2945, Dec. 2007.
- [17]. Z. Du, B. Ozpineci, L. M. Tolbert, and J. N. Chiasson, “Inductorless DC-AC cascaded H-bridge multilevel boost inverter for electric/hybrid electric vehicle applications,” in *Proc. IEEE Ind. Appl. Conf.*, 2007, pp. 603–608.

