

AUTOMATIC GENERATION CONTROL OF INTERCONNECTED POWER SYSTEM

KANCHAN LATA BECK, Dr. MITHILESH SINGH, VIJAY PRAKASH GUPTA

Electrical Engineering Department, Shri Rawatpura Sarkar University, Raipur, Chhattisgarh

Abstract :

The present article is aimed to discuss the various operational and control aspects of interconnected power systems. The structure of present day power systems is discussed and it is followed by the identification of automatic generation control (AGC) problem among the overall control of interconnected power systems. The article describes the duties and functional areas of AGC in a power system. The relevant aspects of frequency deviations and associated operating controls, structure of frequency control loops and functions of typical AGC system are described.

Keywords :- Interconnected power systems, Control function hierarchy, secondary and emergency control. EHVAC/DVDC transmission links,

Introduction:-

The challenge of supplying reliable and good quality of electrical energy at a reasonable cost to the consumers is one of the prime objectives of the planners of the nation. The electric power system is one of the oldest infrastructures. The quality, reliability and the cost are important features which provide the basis of attracting consumers in a country. The per capita consumption of electrical energy has been considered as the prime index to evaluate the overall development of any country. In developing countries like India, there has been a wide gap between the electric energy demand and its production. The power engineers

and the government agencies along with public sectors are continuously putting their best efforts to improving infrastructure and minimize this gap. Due to best efforts, this gap has been narrowed down to great extent, but still a gap exists. The installed capacity in India has increased about more than seventy times and annual electricity generation by about ninety five times in more than sixty years after independence. The transmission and distribution network in India have also expanded to the population accordingly. Still electrical power is not sufficiently available to a large section of Indian people living in rural areas. According to projections, the requirement of power will almost be double in the next 15 years [1]. The important reasons for this are exponential growth of population and the continuous all- round development in the country. Therefore, the power engineers, planners, economists and technologists are visualizing the challenges to come in future and searching out the means to meet these challenges effectively.

The installation of electric power generating stations in the country are associated with technological, economic, social, regional, eco-friendly and most importantly the political considerations. Therefore, the power generating stations are located at remote locations from the load centers. However, for economical and technical reasons, most of the systems are electrically interconnected into vast power grids which are subdivided into regional operating groups called power pools. Each individual power system within such a pool operates technically and economically independently, but they are dependent on other pool members in respect to generation and scheduling aspects for which they have binding through a mutual contract. There are

numerous advantages associated with operating in interconnected or pool fashion like; provision of construction of larger and more economical generating units and the transmission of large blocks of energy from the generating sources to major loads, reduced reserves requirements by sharing of capacity between areas and sectors, capacity savings from time zone and random diversity, capacity savings by seasonal exchange of capacity between areas which have opposing winter and summer needs, transmission facility of off-peak energy, flexibility to meet unforeseen emergency demands and importantly to have technical benefits out of the uses of the variability in generation mixes and load patterns.

The operation of power system in an interconnected fashion system usually leads to improved system security also. These benefits have been recognized from the beginning and hence, interconnections between the power pools continue to grow. The duties of the transmission system as an interconnection are not only to handle the largest blocks of power, it also interconnects all the generator stations and all the major loading points in the system. The energy can be routed, generally, in any desired direction on the various links of the transmission system in a way that corresponds to best overall operating economy or best serves a technical objective. Via interties, transport of energy can take place to or from other power systems belonging to the same power pool. For successful, stable and reliable operation of interconnected power system, a technically compatible transmission system to act as pool interconnection is essentially required.

The requirements of compatible interconnection have been successfully fulfilled by EHV AC transmission lines. However, many problems are identified with these types of interconnections when used for long distance transmission of electrical power. To circumvent these, HVDC transmission systems have emerged at power scenario. Already, a considerable number of HVDC transmission links have been laid down and many projects are in progress. It is expected that HVDC transmission lines will have a major share in over all transmission network infrastructure in the years to come. With these

developments, operational and control problems of such systems will be a challenging task for power engineers.

Power System Operation and Control:-

To control the power system in all conditions of operation, there is need for decomposition by operational mode arises. The real time operation of the power system may exist in one of the four operating states namely, normal state, preventive state, emergency state and restorative states. The main objective of power system operation is to keep system in the normal state as long as possible which can be achieved by fulfilling the following conditions;

- All the load flow equations are satisfied and load demands must be met at minimum cost subject to constraints on amount of spinning reserve.
- The operating frequency of power system is constant
- The bus voltage is within narrow prescribed limits.
- Power system components are not overloaded.

Normally, most of the time the power system operates in normal operating states. In this state the power system is operated so that the demands of all consumers are satisfied at standard frequency and voltage. However, the contingencies those are likely to change the operating state of the power system to an emergency state. If a contingencies likely to occur such that power system may not be able to return to the normal state of operation, then the power system operation transits to preventive state of the operation. The assumption here is that by taking corrective action in anticipation the power system can be made to remain in the normal operating state. It is possible and often desirable to combine the normal and preventive modes into a single power system operating mode. If a contingency has occurred such that the consumer demand cannot be maintain at prescribed voltages and frequencies, then the power system transits to

emergency mode of operation while economics is completely sacrificed. Once the power system has gone into emergency mode then the power system has to be brought back to the normal or preventive operating state via the restorative operating mode. The time hierarchy of execution of control functions in power system arises because of the extremely wide range of response time inherent in power system operation and control. Time decomposition is always carried out to subdivide a difficult problem into smaller sub-problems. The overall operation and control of a power system on time scale may be clubbed in four major groups as described by Table-1. In this Table, there are still some slower and faster functions than the time decomposition which are not mentioned here. For example, maintenance scheduling has a time scale of days while relay action is faster than governor action.

Table 1. Time Hierarchy of Control Functions in Power System

Sr. No.	Control functions	Time scale
1	Governor action	Few seconds
2	Automatic generation Control (AGC)	Many seconds
3	Economic dispatching (ED)	Minutes
4	Unit Commitment (UC)	Hours

It often happens that control functions at higher level take place with a slower time scale than control function at a lower level. An example of this is that UC control action takes place at interconnected power system levels while EC, AGC and governor action take place at individual plants level. However, this is not a general rule. For example, boiler control action done at the power plant level can be slower than AGC done at system level. Apart from that, control functions for governor action and AGC are executed as on-line functions while unit commitment and other slower functions (i.e. maintenance, planning etc.) are considered to be executed as off-line functions. The economic dispatch is carried out as on-line and off-line function depending upon the situation. The power system has its variable characteristics in terms of generation, transmission, distribution and utilization. The operation of such power systems is associated with diversified characteristics. However, each utility must have some set of regulations and operating norms mandatory, which must be followed by its control centre for its successful

effective operation and control. Modern power system is a complex system consisting of many interacting subsystems. Several levels of controls are involving complex arrays of devices and are used to meet the requirements of the power system. Fig. 1. represents sub-systems of power systems for its operation and associated control.

This overall structure consists of (i) generating units controls (ii) system generation controls and (iii) transmission controls. Each generating unit has prime mover controls. The controllers of prime mover are designed considering speed regulation and control of energy supply system variables such as boiler pressure, temperature, and flows. However, the generator voltage and reactive power output is regulated by excitation control while the desired MW outputs of the individual generating units are obtained by the system generation control.

The prime objective of the generating unit controls is to balance the total system generation against system load and losses so that the desired frequency and power interchange with neighbouring control areas is maintained. The transmission controls consist of power and voltage control devices, such as static VAR compensators, synchronous condensers, switched capacitors and reactors, tap-changing transformers, phase-shifting transformers, and HVDC transmission controls. As described above, the controls of power system contribute to the satisfactory operation of the power system by maintaining system voltages and frequency and other system variables within their acceptable limits.

Automatic Generation Control:-

In a power system, the frequency deviations are mainly due to real power mismatch between generation and load, whereas voltage variations are due to reactive power imbalance in the system. The reactive power is produced close to requirements as it involves only capital cost but no fuel cost and it is not exported on the lines to avoid large transmission losses. However, for successful operation of a power system active power balance

can be achieved by controlling the generation and it is called automatic generation control (AGC). The control loops of these two parameters, therefore, assumed to be decoupled. Moreover, a sustained frequency deviation directly affects power system operation, security, reliability, and efficiency by damaging equipment, degrading load performance, overloading transmission lines, and undesirable triggering of the power system protection devices.

The AGC is a significant control process that operates constantly to balance the generation and load in power systems at a minimum cost. The AGC is responsible for frequency control and power interchange, as well as economic dispatch. AGC provides an effective mechanism for adjusting the generation to minimize frequency deviation and regulate tie-line power flows. The AGC system realizes generation changes by sending signals to the under-control generating

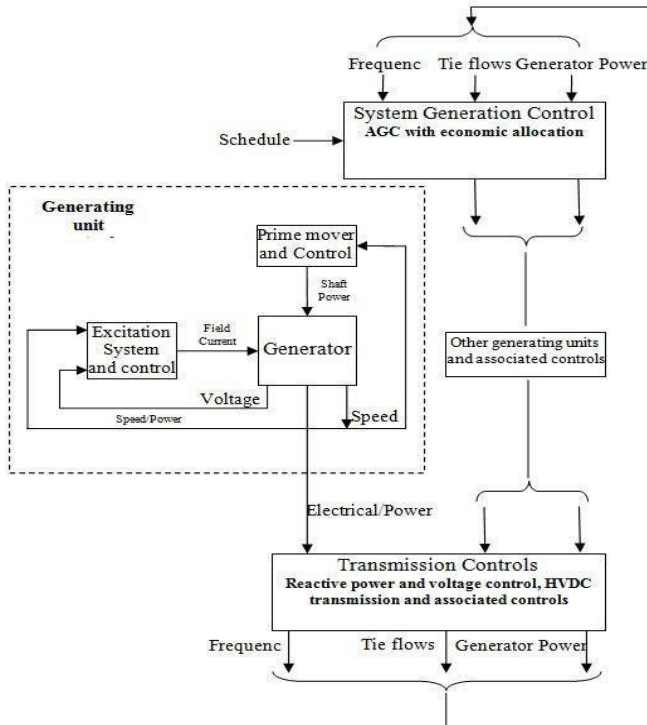

units. The performance of an AGC system is highly dependent on how quickly and effectively generating units respond to the commands. However, the response characteristics of generating unit are associated with numerous factors, such as type of unit, fuel, control strategy, and operating point. Since the frequency generated in the power system network is

proportional to the rotation speed of the generator, the problem of frequency control may be directly converted into a speed control problem of the turbine generator unit. This is initially done by augmenting a governing mechanism that senses the generator speed, and adjusts the input valve for changing the mechanical power output to track the load change and for restoring nominal frequency value.

Frequency Deviations and Associated Controls:-

The primary, secondary and emergency control are classified based on the magnitude of frequency deviations. These are shown Fig. 2. For a typical power system operating at 50 Hz nominal frequency, the ranges of frequency deviations and type of control actions are described in Table-2. The accepted standard value of frequency in Hz is also shown by Table-2.

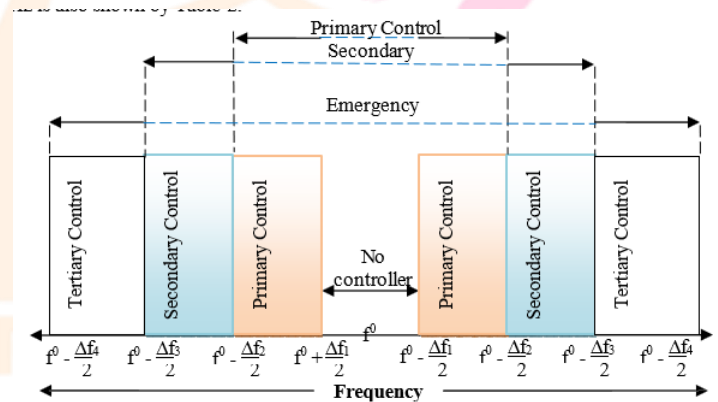

Fig. 2. Frequency deviations and associated operating controls

Sr. No.	Range of frequency (F)	Range of frequency at 50 Hz	Types of operation	Types of Control
1	$f^0 - \frac{\Delta f_1}{2}$ to $f^0 + \frac{\Delta f_1}{2}$	50.05 to 49.95	Normal	No controller is required
2	$f^0 - \frac{\Delta f_2}{2}$ to $f^0 + \frac{\Delta f_2}{2}$	50.20 to 50.05 and 49.8 to 49.95	Normal operation	Primary control
3	$f^0 - \frac{\Delta f_3}{2}$ to $f^0 + \frac{\Delta f_3}{2}$	50.20 to 51.00 and 49.80 to 49.00	Off-normal operation	Secondary control (AGC)
4	$f^0 - \frac{\Delta f_4}{2}$ to $f^0 + \frac{\Delta f_4}{2}$	above 51.00 and below 49.00	Emergency operation	Emergency control

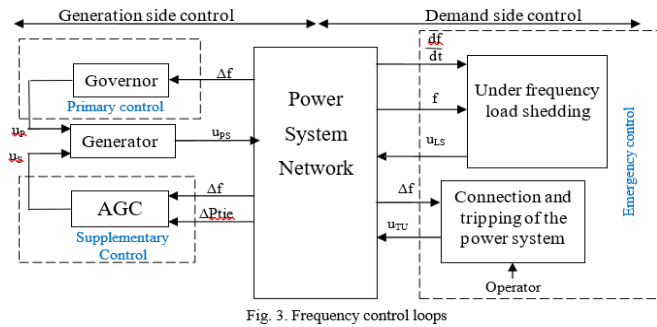

Fig. 3. Frequency control loops

The nominal frequency f_0 and frequency deviations Δf_1 , Δf_2 , Δf_3 and Δf_4 show frequency variation range corresponding to the different operating conditions based on the accepted frequency operating standards. However the natural governor response known as the primary control, the supplementary control (AGC), or secondary control, and emergency control may all be required to maintain successful operation of the power system. The detailed functional block diagram representing primary control loop, supplementary control loop and emergency control loop are shown in Fig. 3. The typical dynamic responses of power system to a generating power plant trip event, with the responses of primary, supplementary and emergency control are plotted in Fig. 4.

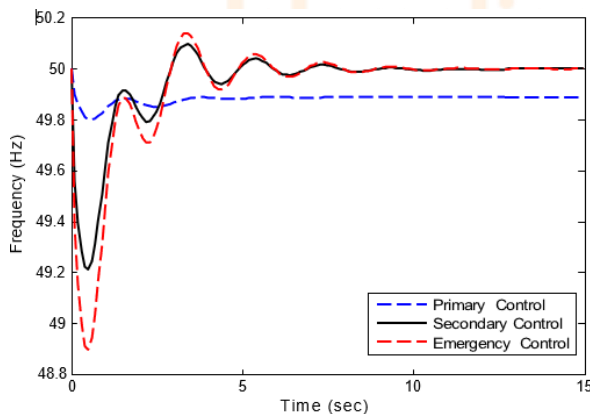

Fig. 4 Primary, secondary and emergency control

Needless to say that for satisfactory operation of a power system, the frequency should remain as near as nominal system frequency. Under normal operation of power system, the small frequency deviations can be controlled by the primary

control loop. Depending on the type of generation, the real power delivered by a generator is controlled by the mechanical power output of a prime mover such as a steam turbine, gas turbine, hydro turbine, or diesel engine. As shown in Fig. 3, a synchronous generator is equipped with a primary frequency control loop. The speed governor senses the change in frequency (Δf) via the primary control loop. In fact, primary control performs a local automatic control that delivers reserve power in opposition to any deviation in nominal frequency. The speed changer in speed governing system provides an incremental change (up) in steady state power output setting for the turbine. The speed governor on each generating unit provides the primary speed control function, and all generating units contribute to the overall change in generation, irrespective of the location of the load deviations, using their speed governing. However, primary control action is not normally found adequate to restore the system frequency, particularly in an interconnected power system, and the supplementary control loop is required to handle the situation.

For larger frequency deviation, AGC is responsible for regulating system frequency. In addition to primary frequency control, a large synchronous generator may be equipped with a supplementary frequency control loop. The combination of frequency deviation (Δf) and tie-line deviation (ΔP_{tie}) is called area control error (ACE). The supplementary loop gives feedback via ACE and incremental change (u_s) adds it to the primary control loop through a dynamic controller. The incremental change in power generation function (u_{PS}) is obtained from the generator by using its input signals u_p and u_s from primary and secondary control loops respectively. Following a significant fault, there is a serious load-generation imbalance associated with rapid frequency changes. The AGC regulator may not be able to restore frequency via the secondary control loop. In this situation, the emergency control and protection schemes, such as under-frequency load shedding (UFLS), are to be initiated to reduce the risk of cascaded contingencies which may lead to interruption of power supply. In case of emergency control, UFLS and protection system act as a tertiary

control. Whenever secondary control system fails to regulate undesirable change in operating condition, the UFLS control system senses the signals (frequency and its derivative) and produce appropriate increment function (uLS) for load shedding while protection unit produced increment change (uTU) for tripping of the power system network to get the power system in nominal state.

Functions of AGC System in an Interconnected Power System:-

Typical AGC Systems In modern AGC schemes, the control actions are usually determined for each control area of a power system at dispatch centre. Fig. 5 describes the functional diagram of a typical AGC system. The power system is interconnected via tie-lines. In a control area all the generators not taking parts in AGC rather than only few generators contribute for AGC. The functional diagram of AGC system is consisting of control areas, economic dispatch centre (EDC) and various components of AGC system. The EDC receives daily schedule for generators, dispatch the power economically and updates the schedule of power units in every 5 minutes.

Information pertaining to tie line flows, system frequency, and unit MW loadings is telemetered to dispatch centre, where the control actions are determined by a digital computer. However, the control equipment at the power plants changes the reference set-points of the units up or down in proportion to the pulse length. With the measurement of tie-line flow, its deviation, frequency deviation in ACE are obtained and raise/lower control signal is given to the generation units (units which are on AGC) in every 1-2 sec for control of power units.

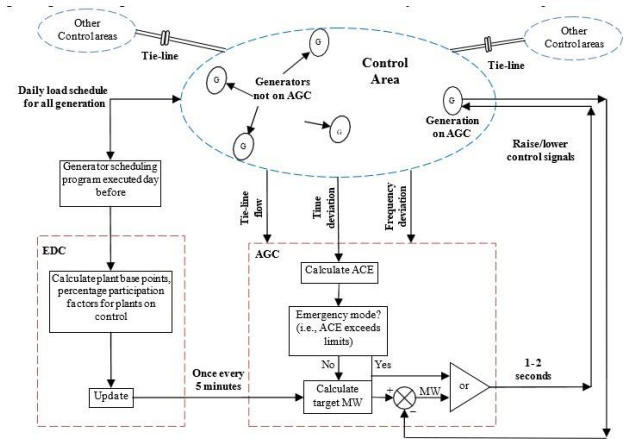

Fig. 5 Functional diagram of typical AGC system

Overview and Conclusions:-

An overview of structure of modern power systems is discussed comprehensively with due attention on the requirement of proper type of interconnections for effectively delivering the electrical power to the loads/ consumers located at very far away from generating stations. The AGC problem in an interconnected power system and its various aspects are also identified. The duties and functions of AGC schemes are also highlighted so that AGC schemes can be designed and implemented effectively.