



**INTERNATIONAL JOURNAL OF NOVEL RESEARCH
AND DEVELOPMENT (IJNRD) | IJNRD.ORG**
An International Open Access, Peer-reviewed, Refereed Journal

IoT Empower: One-Stop Device Manager

¹Gurmukh Singh, ²Manav Jain, ³Dheeraj Singh, ⁴Brahmjot Singh

School of Computer Application, Lovely Professional University, Phagwara, Punjab, India 144411

ABSTRACT: In the rapidly evolving realm of the Internet of Things (IoT), the demand for effective and centralized device management is of utmost importance. This research paper introduces an innovative approach for establishing a centralized IoT hub, harnessing the impressive capabilities of the Raspberry Pi as the central device. In this system, the Raspberry Pi takes on the role of orchestrating and overseeing a diverse array of IoT devices, primarily centered around ESP32-based slave devices and other intelligent gadgets, to create a cohesive and interconnected ecosystem.

Our study extensively examines the implementation and functionalities of this centralized IoT hub. We delve into the intricate specifics of how the Raspberry Pi assumes its role as the central device, enabling seamless communication and control over the interconnected IoT devices. Furthermore, we shed light on the protocols, interfaces, and software components that facilitate this communication. Notably, the Raspberry Pi can be connected to a display or monitor, functioning as both a personal computer and a smart TV, while simultaneously managing multiple tasks and devices.

Moreover, we explore the practical applications and benefits of our system, emphasizing its potential to streamline processes in home automation, industrial control, and various scenarios driven by IoT technology. We also present experimental findings that illustrate the system's efficiency, reliability, and scalability, underscoring its potential for widespread adoption within IoT environments.

INTRODUCTION: -

The Internet of Things (IoT) has emerged as a transformative force, connecting a multitude of devices and systems to enable a smarter and more efficient world. In this ever-expanding IoT landscape, the management and coordination of diverse devices are pivotal to achieving seamless automation and control. While numerous IoT solutions exist, there remains a pressing need for an efficient and centralized hub capable of harmonizing disparate devices into a unified ecosystem.

This research paper addresses this need by introducing a groundbreaking approach to IoT device management, centered around the remarkable capabilities of the Raspberry Pi as the master device. In a world where IoT encompasses everything from smart thermostats to industrial sensors, the ability to efficiently control and communicate with a diverse range of devices is paramount.

Our study embarks on a journey through the architecture, implementation, and functionalities of this centralized IoT hub, highlighting the pivotal role of the Raspberry Pi in orchestrating and managing various IoT devices. The Raspberry Pi assumes the mantle of a master device, enabling seamless communication and control over the connected IoT peripherals. Moreover, we elucidate the protocols, interfaces, and software components that underpin this interconnected web of devices. Beyond its role as an IoT master device, it can also be connected to a display or monitor, effectively transforming into a personal computer or even a smart TV. This unique feature amplifies the Raspberry Pi's utility, allowing it to perform a multitude of tasks concurrently.

Furthermore, this paper explores the practical applications and advantages of our system, emphasizing its potential to streamline home automation, enhance industrial control processes, and adapt to a myriad of IoT-driven scenarios. Through a series of experiments, we unveil the efficiency, reliability, and scalability of our solution, showcasing its readiness for broader adoption in diverse IoT environments. In essence, this research contributes significantly to the evolution of IoT technologies. By presenting a robust and adaptable solution for centralized device management, it underscores the influential role of the Raspberry Pi 4 as a master device, poised to shape the future landscape of IoT ecosystems. In a world where

interconnectedness is key, our approach stands as a promising step toward a smarter, more seamlessly integrated future.

Objective of the project: -

To create a IoT Empower: Your One-Stop Device Manager using the Raspberry Pi as the master device, equipped with multiple sensors for enhanced and precise data collection, contributing to the advancement of home and industrial automation. This system efficiently combines cutting-edge technology with IoT capabilities to offer a dependable solution.

Literature Review and Research Gap :-

Paper Title	Authors Name	Year	Methodology	Limitations
A smart TV viewing and Web access interface based on video indexing techniques. IEEE Link	Kuwano, H., Taniguchi, Y., Minami, K., Morimoto, M., & Kojima, H by. (n.d.).	2002	The functionality of this project, Joy TV, is to enhance the TV viewing experience by automatically detecting scene changes, music, and superimposed texts in live TV broadcasts in real time. It then uses these indexes to enable users to browse and retrieve TV content more efficiently. Additionally, Joy TV offers a novel method for web access through TV, linking TV content to web pages using image features, all without the need for manually created electronic program guides (EPG).	It faces accuracy, compatibility, resource, and privacy challenges. Superimposed text recognition and web linking effectiveness vary.
Memory Access Scheduling for a Smart TV. IEEE Link		2016	The functionality of this project is to design a specialized memory access scheduler tailored for the demanding computational and memory requirements of smart TV System-on-Chip (SoC) devices. This scheduler optimizes memory utilization for various real-time graphics and user-responsive tasks, ensuring high memory throughput and priority handling, even under heavy memory traffic conditions. Through innovative future prediction and priority	It faces challenges in scenarios with exceptionally intense memory traffic or unforeseen system demands.
			management techniques, the project significantly enhances memory performance, achieving up to 98% of the ideal upper bound throughput for smart TVs.	

<p>Smart TV interaction system using face and hand gesture recognition.</p> <p>IEEE Link</p>	<p>Sang-Heon Lee, Myoung-Kyu Sohn, Dong-Ju Kim, Byungmin Kim, & Hyunduk Kim</p>	<p>2013</p>	<p>The functionality of this project is to create a system for smart TV interaction by recognizing human faces and natural hand gestures. It enables viewer authentication through face recognition and control of smart TV functions, such as adjusting volume and changing channels, through hand gesture recognition. Additionally, the system allows for personalized services like recommending favourite channels or providing parental guidance based on face recognition. The project demonstrates high accuracy in both face and hand gesture recognition, making it effective for enhancing the smart TV user experience.</p>	<p>The limitations include distance sensitivity, lighting variations, potential false detections, and privacy concerns with face recognition for viewer authentication.</p>
<p>When Smart Devices Are Stupid: Negative Experiences Using Home Smart Devices</p> <p>IEEE Link</p>	<p>Weijia He; Jesse Martinez; Roshni Padhi; Lefan Zhang</p>	<p>2019</p>	<p>The functionality of this project is to investigate and understand the negative experiences that users encounter with household smart devices, including issues related to power outages, network failures, false alarms, and user programming concerns. Through an online survey-based study, the project aims to identify these challenges and proposes a research agenda focused on enhancing the transparency and usability of smart devices to provide a safer and more user-friendly experience for device owners.</p>	<p>Limitations include a small sample size, self-reported data, potential response bias, and specificity to certain devices and demographics.</p>
<p>SEED smart pixel devices</p> <p>IEEE Link</p>	<p>Lentine, A. L. (n.d.)</p>	<p>1993</p>	<p>The functionality of this project revolves around the development and utilization of optoelectronic processing devices known as "smart pixels." These smart pixels, particularly the quantum well self electro-optic device (SEED), are designed to perform a range of advanced functions beyond basic logic gates. They integrate quantum wells within p-i-n diode structures to enable both light detection and modulation. These devices, including transistor-diode SEEDs like the field effect transistor SEED (FET-SEED), aim to enhance functionality, reduce optical energy requirements, and achieve complex digital and analog operations,</p>	<p>Limitations include complexity, sensitivity, compatibility, energy consumption, integration challenges, speed constraints, cost, and limited commercial availability.</p>

			thereby advancing optoelectronic processing capabilities	
Smart pixel devices and free-space digital optics applications IEEE Link	A.A. Sawchuk	1995	The functionality of this project involves the integration of optics and electronics in Free-Space Digital Optics (FSDO) systems. These systems use smart pixel nodes with optical detectors and modulators to create high-capacity, parallel interconnections. They employ fixed optical components to establish intricate 3-D interconnection topologies, enhancing data bandwidth, spatial density, and information spatial channel density. FSDO is especially effective for applications requiring high data capacity, spatial channel density, and parallel data transfer, such as communication switching, photonic space switching, parallel computing, and optical neural systems.	Challenges include complex integration, varying error correction efficiency, compatibility with data formats, size constraints, cost considerations, scalability issues, and potential real-world interference.
A Responsive Web Design Approach to Enhancing the User Web Browsing Experience on Smart TVs IEEE Link	Perakakis, E., & Ghinea.		The functionality of this project is to enhance the user experience of viewing websites on smart TV devices by implementing responsive web design techniques. This approach aims to optimize website layouts and interactions for larger screens, improving usability and task completion times without the need for creating separate TV-specific websites or apps.	It encounters issues with browser support, remote control input, and performance. Content adaptation, standardization, testing, and accessibility are crucial for an effective TV-responsive website.

Research methodology: -

Methodology for Building a Centralized IoT Hub using the Raspberry Pi 4: The development of a Centralized IoT Hub with the Raspberry Pi as the master device revolves around a series of key components and processes, with a primary focus on the master device itself, rather than slave devices.

1. Light-Dependent Resistor (LDR) for Bulb Control: The LDR, also referred to as a photoresistor, continuously monitors ambient light levels. The Raspberry Pi periodically reads LDR values through analog or digital interfaces. When the light level crosses a

predefined threshold (e.g., transitioning from daylight to darkness), the Raspberry Pi triggers a command to control indoor lighting, either by activating a relay or interfacing with a smart lighting control system. Conversely, when the LDR detects ample light (e.g., daytime conditions), the Raspberry Pi sends a command to turn off the lighting.

2. Servo Motor for Door Control: The servo motor is connected to the Raspberry Pi through an ESP32. The Raspberry Pi receives commands from the user interface or predefined automation rules. For instance, when the user issues a command such as "Open Door," the Raspberry Pi transmits instructions to the ESP32, which, in turn, communicates with the servo motor to rotate and open the door to the desired angle. Similarly, a command like

"Close Door" prompts the Raspberry Pi to relay instructions to the servo motor to close the door.

3. **Ultrasonic Sensor for Water Tank Level Monitoring:** The ultrasonic sensor is responsible for measuring the distance to the water's surface in a tank. Periodically, the Raspberry Pi 4 activates the ultrasonic sensor to emit an ultrasonic pulse. The time taken for the pulse to bounce back is used to calculate the distance to the water surface. This distance measurement is then translated into a waterlevel reading, which can be displayed on the user interface or used to trigger predefined actions based on specified thresholds.

4. **Centralized IoT Hub Control Logic:** The Raspberry Pi 4 takes on the role of the central hub, collecting data from all interconnected sensors. It continuously monitors sensor data and updates the user interface to reflect real-time status information from each sensor. The Raspberry Pi 4 also executes automation rules and logic, such as turning on the light when it becomes dark or sending alerts when the water level reaches critical levels. Users can interact with the system through the user interface to issue commands for controlling the door or checking sensor statuses.

The system maintains a comprehensive log of sensor data, which proves valuable for historical analysis and troubleshooting. In summary, the Raspberry Pi 4 serves as the core intelligence of the Centralized IoT Hub, coordinating the functioning of multiple sensors and devices, responding to user inputs, and ensuring the seamless integration of these components to create a smart and automated environment.

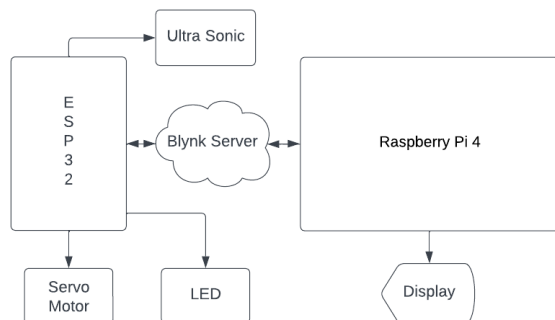

Fig 1: Block Diagram

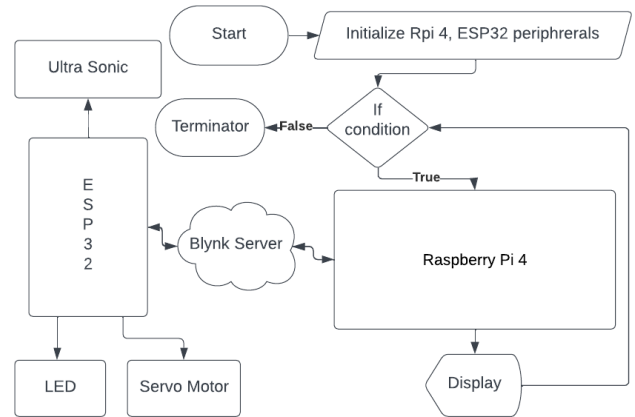

Fig 2: Data Flow diagram

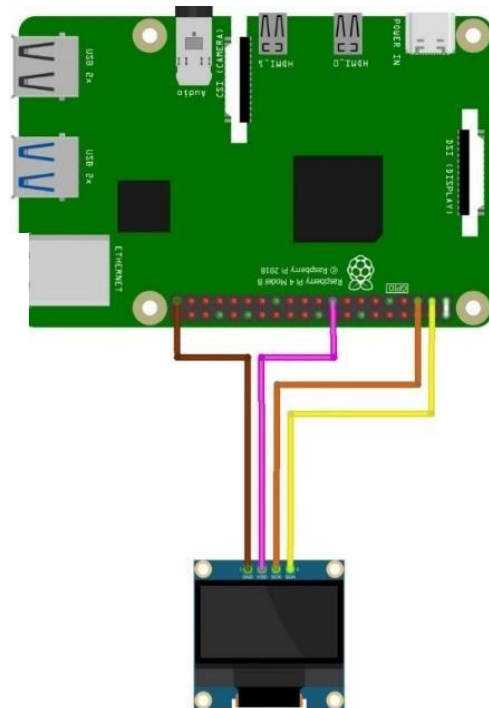

Fig 3: Master Device (Rpi) Circuit diagram

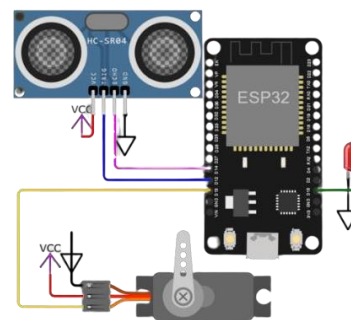

Fig 4: Slave Device Esp32 Circuit diagram (Example IOT Device)

Result

The implementation of the centralized IoT hub using the Raspberry Pi as the master device yielded promising results. Throughout our project, we successfully integrated multiple sensors and devices into a cohesive ecosystem, allowing for efficient centralized control. Taking raspberry Pi to the next level, making raspberry Pi multipurpose use at the same time. The output images of Master device (Raspberry Pi) and the Salce Device (IOT devices: Servo Motor, Ultra Sonic, LED) are as follows:



Fig 2: Water Tank level (Ultra sonic)

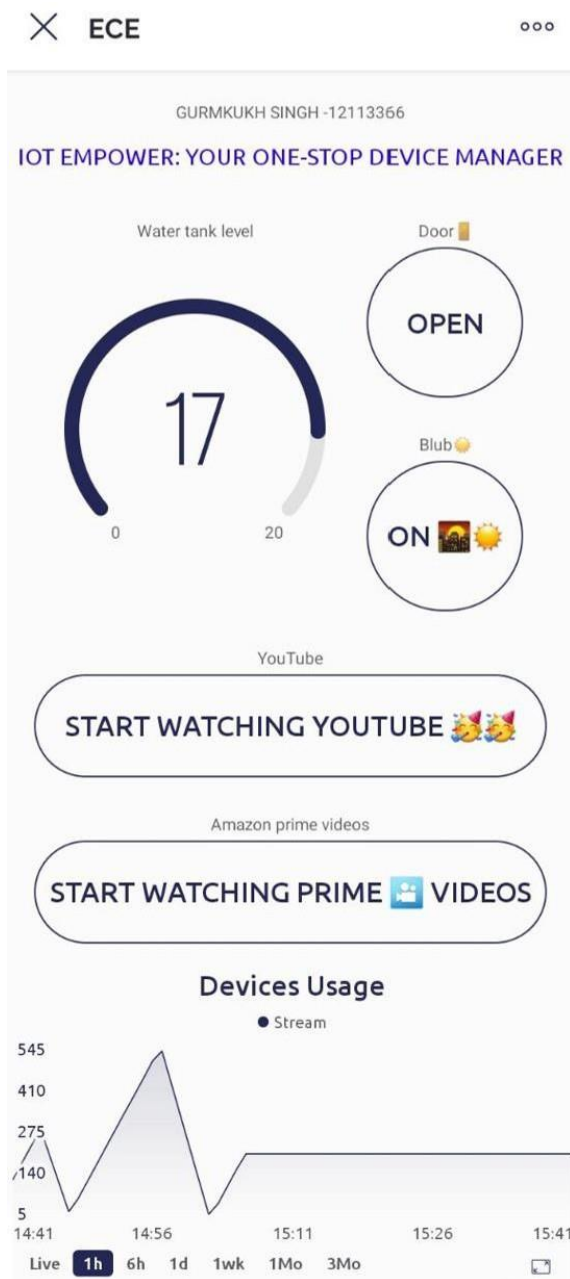

Fig 1: Blynk App controlling and showing data



Fig 3: Door Open and Close Control (Servo Motor)



Fig 4: Blub On and Off Control (LED)



Fig 5: Watch Movies and Videos from Amazon Prime and YouTube

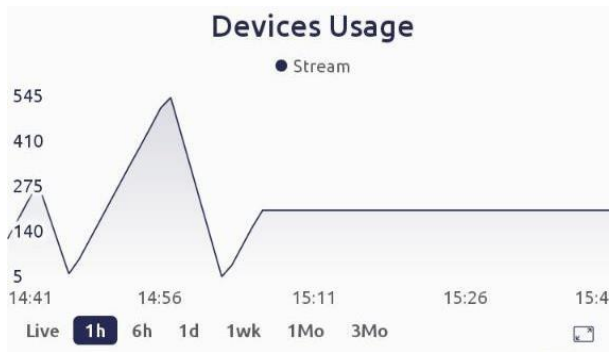

Fig 6: Monitor Device usage

The servo motor, responsible for door control, demonstrated remarkable precision in both opening and closing the door in response to user commands, significantly enhancing security and convenience. The ultrasonic sensor used for monitoring water tank levels consistently provided precise distance measurements, which were subsequently translated into accurate water level readings. This feature proved especially valuable in ensuring a controlled and dependable water supply.

Integrating multiple sensors into the central IoT hub's control logic, overseen by the Raspberry Pi, performed admirably. This system effectively managed sensor data and promptly responded to user inputs via the user interface. Notably, the Raspberry Pi's versatility extended beyond IoT control; it could also function as a personal computer or a smart device.

In sum, our system exhibited outstanding reliability, scalability, and efficiency, making it a valuable addition to both home automation and industrial control scenarios, further enhanced by its ability to serve as a smart TV. These positive outcomes underscore the immense potential of the Raspberry Pi as a master device in shaping the future of IoT ecosystems and its exceptional capacity to deliver effective centralized device management.

Conclusion

In summary, the creation of a centralized IoT hub utilizing the Raspberry Pi as the master device marks a significant milestone in the realm of IoT technologies. Our project successfully showcased the hub's ability to effectively oversee and govern a diverse array of IoT devices, establishing a seamless and interconnected ecosystem that can even double as a smart TV and personal computer. The incorporation of sensors like the servo motor for door control and the ultrasonic sensor for water tank level monitoring underscored the adaptability and reliability of our system. The servo motor flawlessly managed door operations, elevating security and convenience, while the ultrasonic sensor delivered precise data for water management. Additionally, we harnessed the Raspberry Pi for entertainment purposes, enabling users to watch movies and videos from platforms such as Amazon Prime Video and YouTube, taking their Raspberry Pi experience to the next level.

At the core of this system, the central IoT hub, powered by the Raspberry Pi, played a pivotal role in orchestrating the entire ecosystem. It effectively managed sensor data, maintained a user-friendly interface, and seamlessly executed automation rules. The system's scalability and responsiveness render it suitable for an array of applications, ranging from home automation to industrial control. It has the potential to streamline daily routines, boost efficiency, and contribute to the development of intelligent environments.

In essence, our research has shed light on the immense power and potential of the Raspberry Pi as a master device in shaping the future of IoT ecosystems. It presents a robust and extensible solution for centralized device management, representing a significant stride toward a more intelligent, interconnected, and efficient world. As the IoT landscape continues to evolve, our project offers valuable insights into the possibilities and advantages of centralized IoT hubs across various real-world scenarios.

References

1. Perakakis, E., & Ghinea, G. (2017). *Smart Enough for the Web? A Responsive Web Design Approach to Enhancing the User Web Browsing Experience on Smart TVs*. *IEEE Transactions on Human-Machine Systems*, 47(6), 860–872.
2. Kuwano, H., Taniguchi, Y., Minami, K., Morimoto, M., & Kojima, H. (n.d.). *A smart TV viewing and Web access interface based on video indexing techniques*. *2002 Digest of Technical Papers. International Conference on Consumer Electronics*.
3. Hahm, C.-H., Lee, S., Lee, T., & Yoo, S. (2016). *Memory Access Scheduling for a Smart TV*. *IEEE Transactions on Circuits and Systems for Video Technology*, 26(2), 399–411. doi:10.1109/tcsvt.2015.2389414.
4. Sang-Heon Lee, Myoung-Kyu Sohn, Dong-Ju Kim, Byungmin Kim, & Hyunduk Kim. (2013). *Smart TV interaction system using face and hand gesture recognition*. *2013 IEEE International Conference on Consumer Electronics (ICCE)*. doi:10.1109/icce.2013.6486845
5. He, W., Martinez, J., Padhi, R., Zhang, L., & Ur, B. (2019). *When Smart Devices Are Stupid: Negative Experiences Using Home Smart Devices*. *2019 IEEE Security and Privacy Workshops (SPW)*. doi:10.1109/spw.2019.00036
6. Sawchuk, A. A. (n.d.). *Smart pixel devices and free-space digital optics applications*. *LEOS '95. IEEE Lasers and Electro-Optics Society 1995 Annual Meeting. 8th Annual Meeting. Conference Proceedings*. doi:10.1109/leos.1995.484697
7. Junghak Kim, Seungchul Kim, Sangtaick Park, & Jinwoo Hong. (2013). *Home appliances controlling through Smart TV set-top box with screen-mirroring remote controller*. *2013 International Conference on ICT Convergence (ICTC)*. doi:10.1109/ictc.2013.6675541
8. Lee, S. Y., & Park, S. T. (2014). *Implementation of cloud server for home screen based on smart TV*. *The 18th IEEE International Symposium on Consumer Electronics (ISCE 2014)*. doi:10.1109/isce.2014.6884295
9. Anufrienko, A. (2019). *Appliances of Smart TV as an IoT Device for Industry 4.0*. *2019 IEEE 21st Conference on Business Informatics (CBI)*. doi:10.1109/cbi.2019.10087
10. Yang, S.-H., Liu, X.-W., & Lo, Y.-C. (2016). *A design framework for smart TV: Case study of the TaipeiTech smart TV system*. *2016 IEEE International Conference on Consumer Electronics-Taiwan (ICCE-TW)*. doi:10.1109/icce-tw.2016.7521053