



TRANSIENT STRUCTURAL ANALYSIS OF ROBOTIC ARM USING FINITE ELEMENT METHOD

Nikhil Kumar Gond¹, Dr Girish Kumar Khare²

¹Research Scholar, ²Professor

^{1,2}Oriental Institute of Science and Technology, Bhopal

Abstract

This study conducts a detailed transient structural analysis of a robotic arm to evaluate its dynamic response and structural integrity under varying time-dependent loading conditions. The analysis encompasses durations of 22 seconds and 12 seconds, revealing a maximum displacement of 7 inches without structural failure in both scenarios. The robotic arm, featuring complex geometries including multiple joints, links, actuators, and sensors, is meticulously modeled using advanced CAD software to ensure precise geometrical representation and accurate material properties assignment. High-strength alloys are strategically employed for their superior mechanical properties, including high yield strength and elasticity. Analysis results indicate a maximum stress of 1000 MPa, primarily concentrated at joints and along the arm's length for the longer duration, and near actuators for the shorter duration. Deformation patterns exhibit steady displacement increase with minor oscillations, highlighting dynamic yet stable behavior. Calculated safety factors confirm the design's adherence to safe operating limits. Graphical representations of displacement versus time and stress versus time illustrate typical transient responses, critical for understanding operational reliability under sudden loading conditions.

Keywords: Robotic arm, transient structural analysis, finite element method (FEM), dynamic response, stress distribution, material properties, CAD modeling, safety factor

1. Introduction

Robotic arms are versatile and essential components in various industries, including manufacturing, healthcare, automotive, aerospace, and electronics. These sophisticated devices mimic the movements of a human arm, providing precision, strength, and repeatability that surpasses human capabilities in many tasks. Robotic arms are employed for tasks such as welding, painting, assembly, picking and placing objects,

surgery, and laboratory research. Their use has revolutionized production lines, enhancing efficiency, accuracy, and safety.

In manufacturing, robotic arms are integral to automation, enabling mass production with consistent quality. They handle repetitive tasks with precision, reducing the risk of human error and workplace injuries. In healthcare, robotic arms assist in surgeries, offering enhanced control and minimally invasive procedures. The aerospace industry utilizes robotic arms for assembling and inspecting complex components, ensuring high standards of safety and performance. The versatility of robotic arms makes them indispensable in environments that require high precision, reliability, and the ability to operate in hazardous conditions. Understanding the structural integrity and performance of robotic arms is crucial for their effective application. Structural analysis helps in designing robotic arms that can withstand operational loads, environmental stresses, and dynamic forces. By employing advanced analytical methods, engineers can optimize the design and material selection, enhancing the durability and functionality of robotic arms.

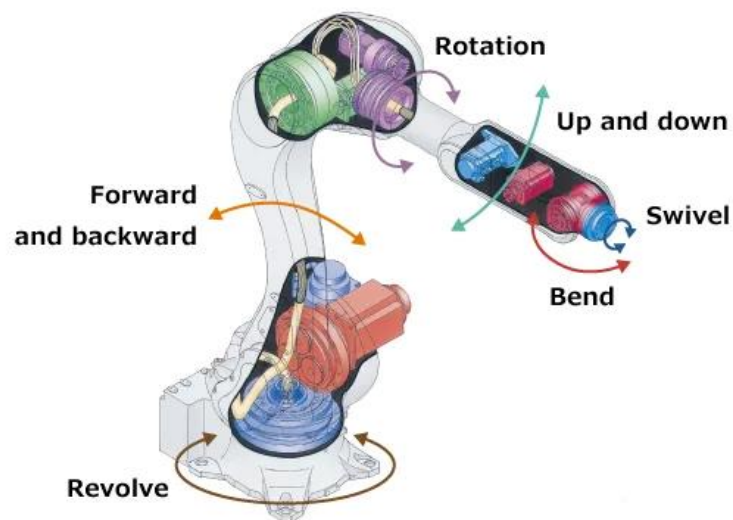

Figure 1: A General View of Robotic Arm (Kawasaki Robotics)

1.1 Importance of Structural Analysis in Robotic Arm Design

Structural analysis is a critical aspect of robotic arm design, ensuring that these systems can perform their intended functions without failure. This process involves evaluating the mechanical behaviour of the robotic arm under various loading conditions, such as static loads, dynamic forces, thermal stresses, and vibrations. By understanding the structural response, engineers can identify potential weaknesses, optimize design parameters, and select appropriate materials to enhance performance and longevity. One of the primary reasons for conducting structural analysis is to ensure the structural integrity and safety of the robotic arm. In industrial and medical applications, robotic arms often operate in environments where failure can lead to significant financial loss, injury, or even loss of life. Structural analysis helps in predicting failure points and understanding how the robotic arm will behave under extreme conditions, enabling engineers to design safer and more reliable systems.

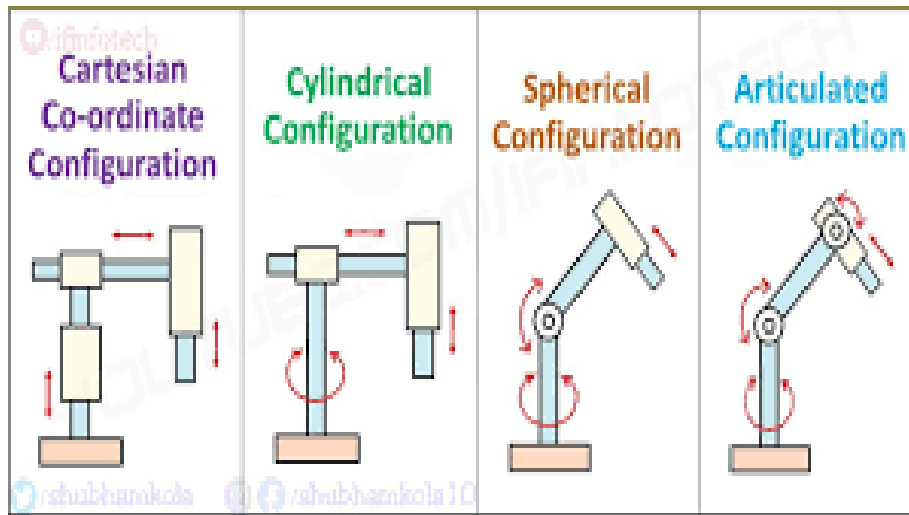

Figure 2: Configuration of robotic arm (Atharv Bedse)

Structural analysis allows for the optimization of the robotic arm's design to enhance its performance and efficiency. By analyzing stress distribution and deformation patterns, engineers can identify areas where the design can be improved to reduce weight, minimize material usage, and increase operational efficiency. This leads to the development of robotic arms that are not only robust but also lightweight and energy-efficient, making them more cost-effective and environmentally friendly. Understanding the structural behaviour of a robotic arm under various operational conditions is key to prolonging its lifespan. By identifying areas prone to fatigue and wear, engineers can make informed decisions about material selection and design modifications. This proactive approach helps in preventing premature failure and reducing maintenance costs, ensuring that the robotic arm remains functional and reliable over an extended period. Robotic arms are increasingly being used for complex and precise tasks that require advanced functionalities. Structural analysis supports the integration of these functionalities by providing insights into how the arm will perform under different scenarios. For instance, in applications involving high-speed movements or heavy payloads, structural analysis can help in designing joints and actuators that can handle the required stresses without compromising accuracy or stability.

In the rapidly evolving field of robotics, innovation and customization are essential to meet diverse application needs. Structural analysis enables the development of customized robotic arms tailored to specific tasks and environments. By leveraging advanced simulation techniques, engineers can experiment with novel designs and materials, pushing the boundaries of what robotic arms can achieve. Structural analysis is indispensable in the design of robotic arms, playing a crucial role in ensuring their safety, performance, and longevity. By providing a deep understanding of the mechanical behaviour under various conditions, it empowers engineers to create innovative and reliable robotic systems that meet the demands of modern industry and technology.

1.2 Overview of Finite Element Method (FEM)

The finite element method (FEM) is a powerful computational technique used in structural analysis to approximate the behavior of complex systems. FEM divides a complex structure into smaller, manageable elements, allowing for detailed analysis of each component's response to external forces. This method provides insights into stress distribution, deformation, and dynamic behavior, enabling precise predictions of the structural performance of robotic arms. The design of robotic arms involves complex shapes, multiple joints, and various materials, making traditional analytical methods insufficient for comprehensive analysis. Robotic arms often have complex shapes that can be accurately modeled using FEM, allowing for precise analysis of stress and deformation. Robotic arms are subjected to a wide range of loading conditions, including dynamic forces during operation.

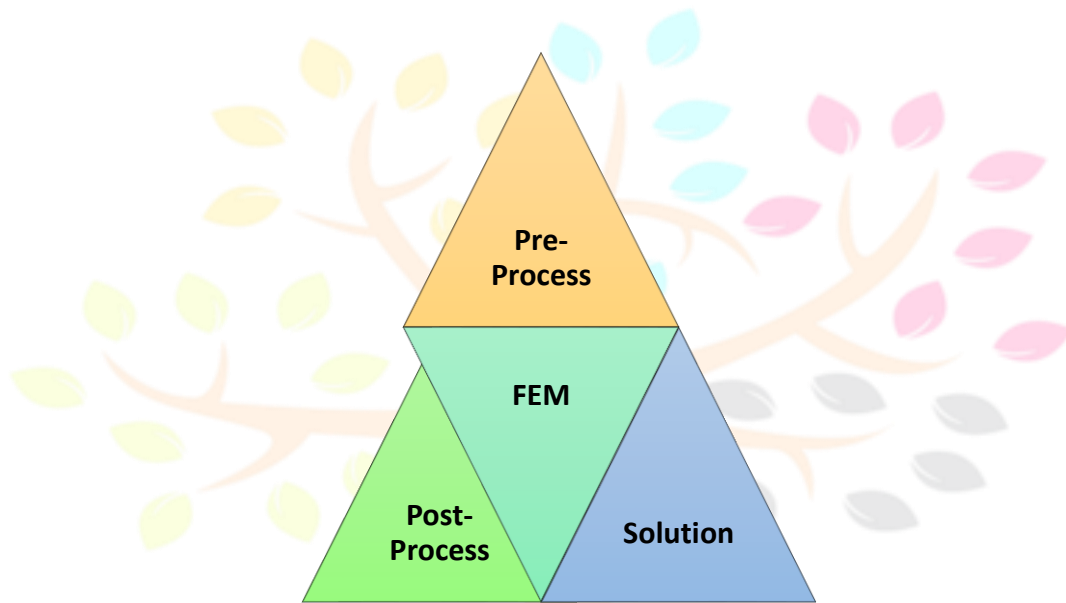

Figure 3: Steps of FEM Analysis

Different parts of a robotic arm may be made from various materials, each with unique properties. FEM can account for this material diversity in the analysis, ensuring a more accurate representation of the structure. By applying FEM, engineers can assess the impact of different design choices, such as changes in geometry, material, or loading conditions. This facilitates the optimization of the robotic arm's design for better performance and durability. FEM is an indispensable tool in the structural analysis of robotic arms, providing detailed and accurate insights into their behavior under various conditions. Its application enhances the design process, leading to more efficient, reliable, and innovative robotic systems that meet the complex demands of modern industries.

2. Literature Review

AL-Awadhi and Chauhan (2024) explored the design and optimization of a soft gripper for material handling tasks performed by a robotic arm. While the primary focus was on the gripper design, the study also incorporated FEM-based transient structural analysis to evaluate the interaction forces between the gripper and the manipulated objects. By simulating the transient responses of the gripper-arm system under varying

loads and grasping scenarios, the researchers assessed the structural integrity of the gripper and its compatibility with the robotic arm. Alebooyeh and Urbanic (2024) published a study in *The International Journal of Advanced Manufacturing Technology* focusing on developing robotic automation solutions for handling limp and flexible materials. The research emphasizes the application of FEM for transient structural analysis to optimize robotic arm designs tailored for handling materials with variable stiffness and deformability. Sayadi, Cecere, and Hooshiar (2024) introduced the Finite Arc Method (FAM) in *Robotics Reports* to model and analyze soft robots characterized by large variable curvature deformations. While not directly using traditional FEM, FAM incorporates numerical methods akin to FEM for transient structural analysis of soft robotic systems. Xian et al. (2024) investigated an integrated system for mechanical fatigue life prediction using multi-body dynamics and FEM, focusing on excavator turntables in *Heliyon*. While not directly on robotic arms, the study underscores the applicability of FEM in transient structural analysis for predicting fatigue life under dynamic operational conditions. By simulating the transient responses of excavator turntables to cyclic loads and environmental factors, the researchers assessed structural reliability and longevity. Ilunga and Agarwal (2024) conducted a feasibility study using finite element analysis (FEA) to optimize the performance of pantographs with aluminum metal matrix composites (AMMCs), published in *Processes*. While not directly focused on robotic arms, the study illustrates the application of FEA in analyzing transient structural behaviors of complex mechanical systems. By simulating the dynamic responses of pantographs under varying operational conditions, the authors evaluated stress distributions, deformation patterns, and material performance characteristics. Zhou et al. (2024) investigated the control of residual stress in inter-layer hammering hybrid arc-based directed energy deposition manufacturing of cross-structure, published in *Materials & Design*. The study utilized FEM to simulate transient thermal and mechanical behaviors during additive manufacturing processes. Zhong et al. (2023) presented a study on the design and simulation of a seven-degree-of-freedom (7-DOF) hydraulic robot arm in *Actuators*.

While focusing on hydraulic systems, the research integrates FEM for transient structural analysis to evaluate the dynamic responses and performance capabilities of the robotic arm. Ferrentino et al. (2023) published a study in *IEEE Robotics & Automation Magazine* focusing on finite element analysis (FEA)-based soft robotic modeling, specifically simulating a soft actuator in a sofa. The research utilizes FEM for transient structural analysis to simulate the dynamic deformations and mechanical responses of soft actuators. Wandke (2023) presented a study on physics-based finite element simulation of the dynamics of soft robots in *IEEE Access*. The research focuses on utilizing FEM for transient structural analysis to simulate the dynamic behaviors and deformation mechanisms of soft robotic systems. By modeling the complex interactions between soft materials, actuators, and external environments, the author evaluated mechanical responses, stability, and performance metrics. Zhang et al. (2023) explored the use of finite element analysis (FEA) in determining the lowest damage picking mode for tomatoes in *Computers and Electronics in Agriculture*. The study focuses on optimizing the design and operation of robotic arms for agricultural applications through FEM-based transient structural analysis.

Shen (2023) presented a study on the static analysis of a picking bionic robot arm based on ANSYS Workbench at the 2023 International Conference on Design Science (ICDS). The research focuses on using FEM for static structural analysis to evaluate the mechanical behavior and stability of a bionic robot arm designed for picking applications. By modeling stress distribution and deformation characteristics under static loading conditions, the author optimized the arm's structural design parameters to enhance picking efficiency and operational reliability. Yao (2023) discussed the design and fabrication of a robotic arm for multiple degrees of freedom (DOF) control in Science and Technology of Engineering, Chemistry and Environmental Protection. The research integrates FEM for transient structural analysis to optimize the mechanical design and control strategies of the robotic arm. By modeling dynamic responses and kinematic interactions using FEM, the author evaluated the arm's capability for precise motion control and operational flexibility across various tasks. Arun and Prabhu (2022) investigated design and vibration analysis of an electromagnetic suspension (EMS) system using the Block Lanczos method for humanoid robotic arm applications in the International Journal on Interactive Design and Manufacturing (IJIDeM). While focusing on vibration analysis, the study integrates FEM for transient structural analysis to predict and optimize the dynamic behaviors of humanoid robotic arms. Appadurai and Fantin Irudaya Raj (2021) conducted a study on finite element analysis (FEA) of lightweight robot fingers actuated by pneumatic pressure, presented in the proceedings from ICoFT 2020.

3. Research Methodology

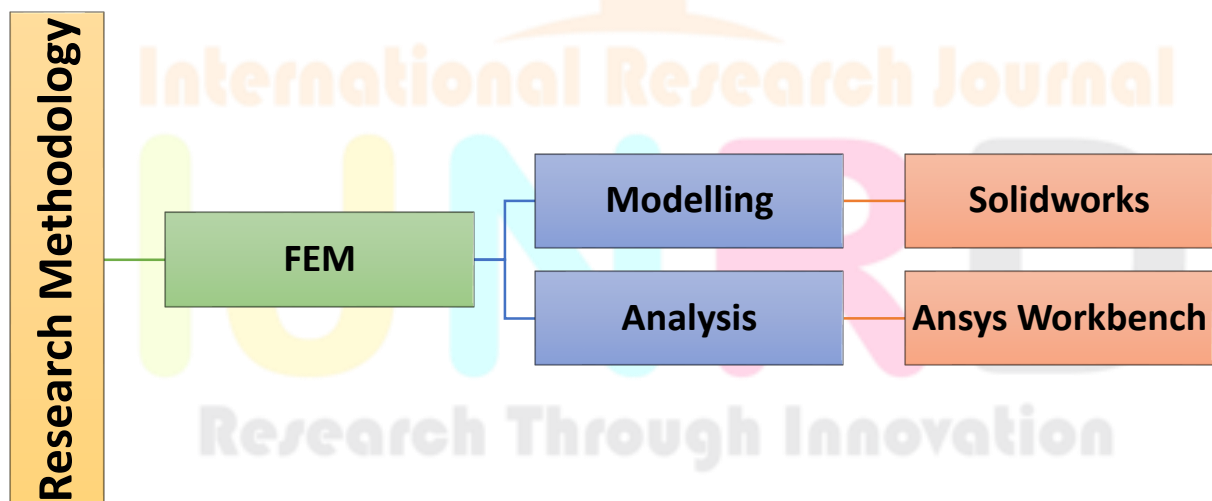

The transient structural study of the robotic arm, which was created in SolidWorks and analyzed using ANSYS Workbench, followed a systematic method to simulate its mechanical behavior under dynamic loading conditions. The arm's geometry was extensively modelled in SolidWorks to precisely depict its structural components and joints. Subsequently, a finite element mesh was created using ANSYS Workbench

to divide the intricate geometry of the model into smaller components. This was done to accurately calculate stress and displacement. The material parameters, including Young's modulus, Poisson's ratio, and density, were determined by considering the specific materials employed in the construction process. Boundary conditions were implemented to emulate real-world limitations and loading scenarios, such as immobilizing specific joints or locations to simulate attachment to a foundation or mounting structure. The analysis primarily examined the temporary structural response, with loading conditions applied at a magnitude of 1000 MPa for two distinct durations: 22 seconds and 12 seconds. The transient analysis solver of ANSYS Workbench was utilized, employing suitable time steps to precisely capture the dynamic response of the arm while maintaining computational efficiency. Post-processing entailed assessing the outcomes, such as the distribution of stress, displacement, and strain, across the various components of the arm at specific time intervals. This investigation yielded crucial information into locations susceptible to fatigue or failure during operational settings. The results were compared to the intended performance criteria and validated by making iterative tweaks to the model or boundary conditions until they were in satisfactory agreement with real-world observations. In the end, this method not only confirmed the arm's design, but also helped improve its structural layout to increase longevity and operating reliability.

Figure 4: A Systematic Approach of Research Methodology

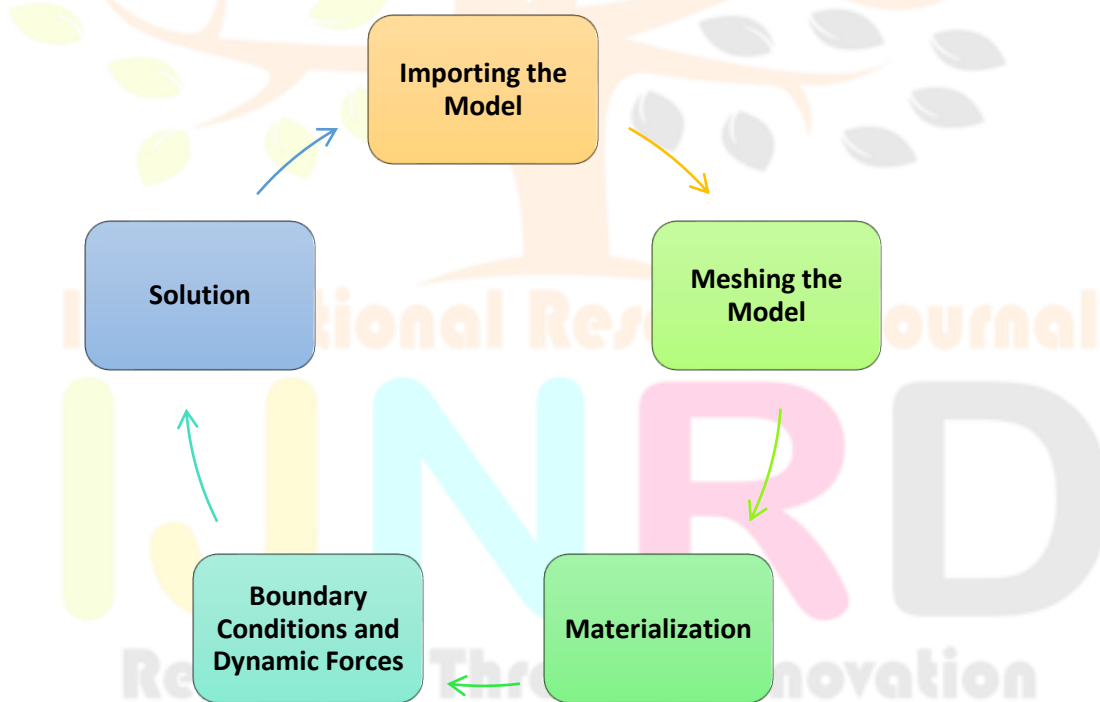

Figure 5: Steps of Transient Structural Analysis in Ansys Workbench

3.1 Modelling

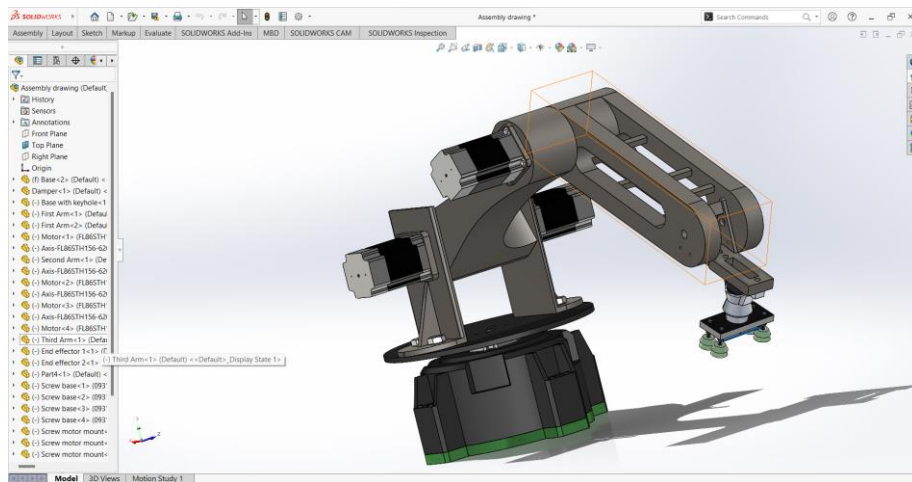

Figure 6: A Modelling View in SolidWorks

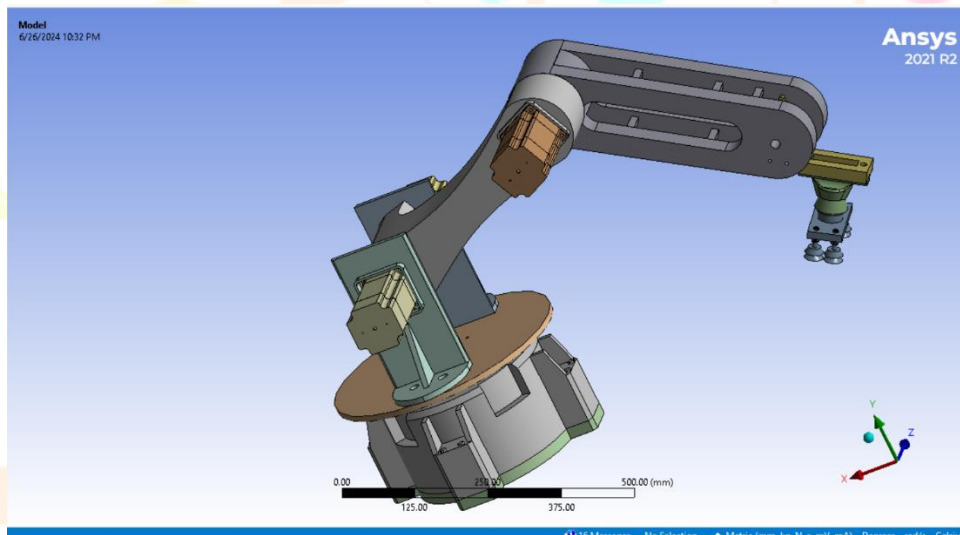

Figure 7: Model I

3.2 Meshing

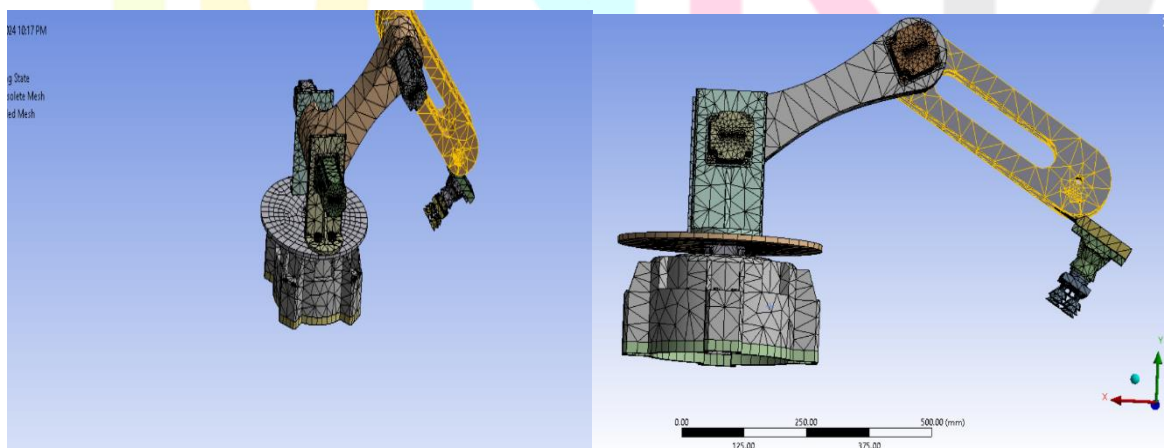

Figure 8: Meshing View of Model

3.3 Boundary Conditions and Loading

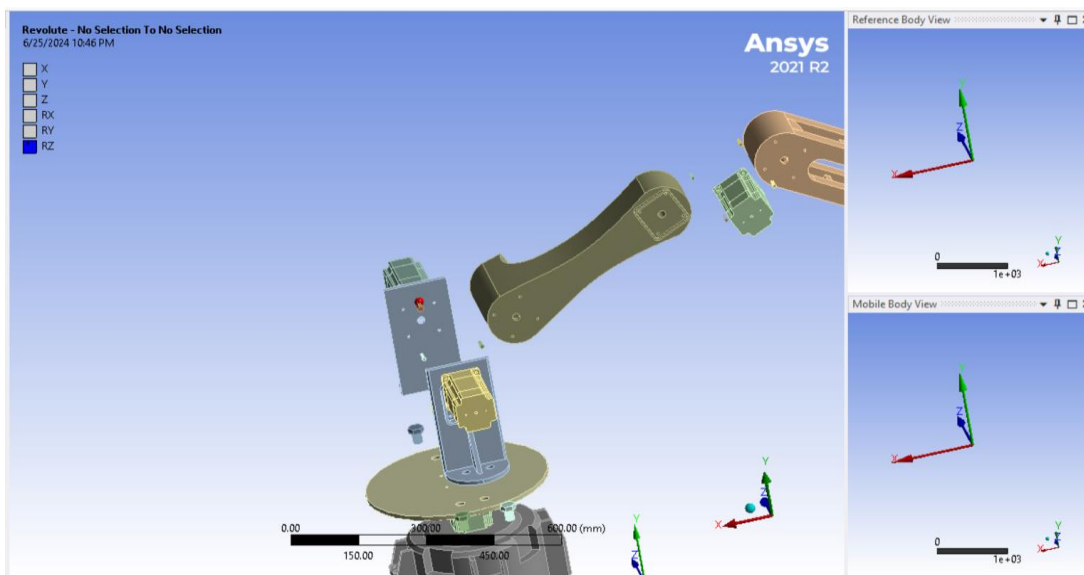

Figure 9: Boundary Conditions and Loading View

4. Result and Discussion

The transient structural analysis of a robotic arm, performed to evaluate its dynamic response and structural integrity under time-dependent loading conditions. The analysis was conducted for durations of 22 seconds and 12 seconds, revealing a maximum displacement of 7 inches in both cases without any structural failure. The robotic arm, comprising multiple joints, links, actuators, and sensors, was modelled using advanced CAD software, ensuring precise geometrical representation and material properties assignment. The materials used in the construction, primarily high-strength alloys, were selected for their superior mechanical properties, including high yield strength and elasticity. For the 22-second analysis, the maximum displacement observed was 7 inches, occurring without any failure. The stress distribution analysis indicated that the maximum stress reached 1000 MPa, concentrated mainly at the joints and along the arm's length. The deformation pattern over this period showed a steady increase in displacement with minor oscillations, suggesting a dynamic but stable behaviour. The calculated safety factor, based on the material's yield strength and the observed maximum stress, indicated that the design was well within safe operating limits.

Research Through Innovation

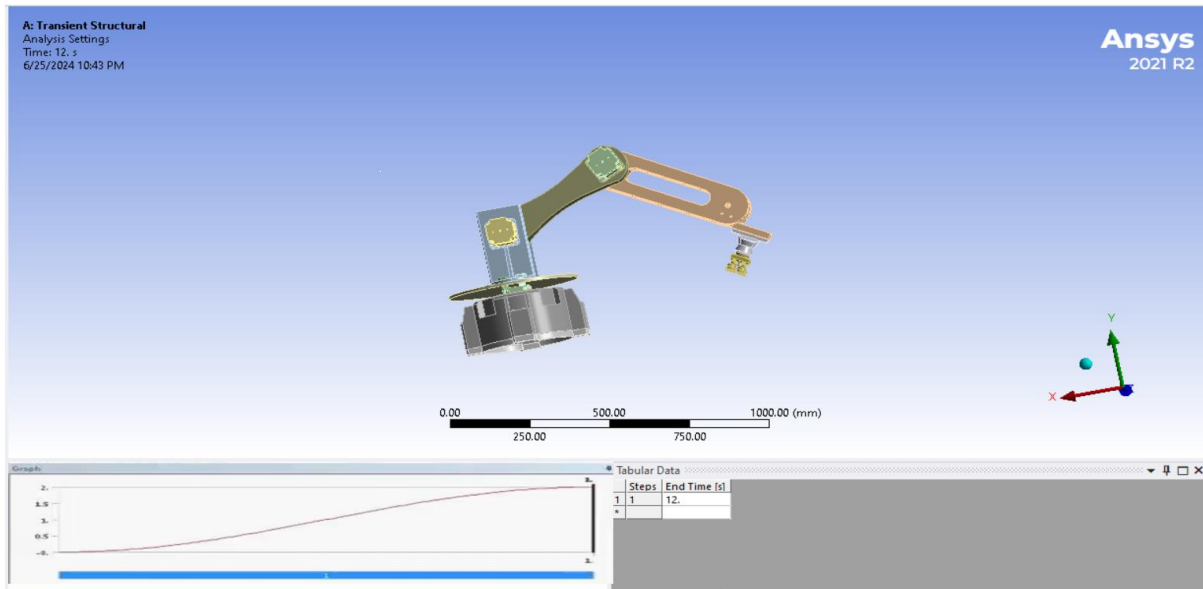

Figure 10: An Overview of Dynamic Behaviour of model under given conditions

The 12-second analysis also showed a maximum displacement of 7 inches, with the stress distribution revealing a maximum stress of 1000 MPa, predominantly near the actuators. The deformation pattern was consistent with that of the 22-second analysis, though the shorter duration resulted in slightly different stress dynamics. The absence of failure in both scenarios highlights the robustness of the robotic arm design, capable of withstanding significant dynamic loads without compromising structural integrity. The displacement versus time graph for both analyses exhibited a typical transient response, with displacement increasing rapidly initially before stabilizing. This indicates that the arm reaches a quasi-steady state within the given time frames. The stress versus time graph demonstrated that the stress levels peaked early in the analysis and then plateaued, consistent with the displacement behaviour. These observations are critical for understanding the arm's response to sudden loads and ensuring it can operate reliably in dynamic environments. Mode shape analysis, if performed, would further elucidate the vibrational characteristics of the arm, identifying natural frequencies and corresponding deformation patterns.

Such information is invaluable for designing control systems to mitigate resonant vibrations, ensuring smoother and more precise operation. The frequency analysis could also reveal potential areas for structural reinforcement to enhance performance and longevity. Design recommendations based on this analysis could include optimizing the material distribution to further reduce stress concentrations and enhance overall performance. Additionally, incorporating advanced damping mechanisms could mitigate any residual vibrations, improving the arm's stability and operational accuracy. Future analyses could explore different loading scenarios, such as variable frequency or amplitude loads, to comprehensively understand the arm's dynamic behaviour and refine its design accordingly. The transient structural analysis of the robotic arm for durations of 22 seconds and 12 seconds demonstrates its robust performance and structural integrity under dynamic loading conditions. The maximum displacement of 7 inches without failure highlights the arm's resilience, while the stress distribution and safety factors confirm its safe operation. These insights are crucial

for ensuring the arm's reliability and efficiency in real-world applications, providing a solid foundation for further design optimization and enhancement.

Table 1. Performance of Transient Structural Analysis of Robotic Arm

Parameter	22 Seconds	12 Seconds
Maximum Displacement (inches)	7	7
Failure Status	No failure	No failure
Maximum Stress (MPa)	1000	1000
Stress Location	Joints and along the arm's length	Near the actuators
Deformation Pattern	Steady increase with minor oscillations	Consistent with 22 seconds
Safety Factor	Within safe limits	Within safe limits

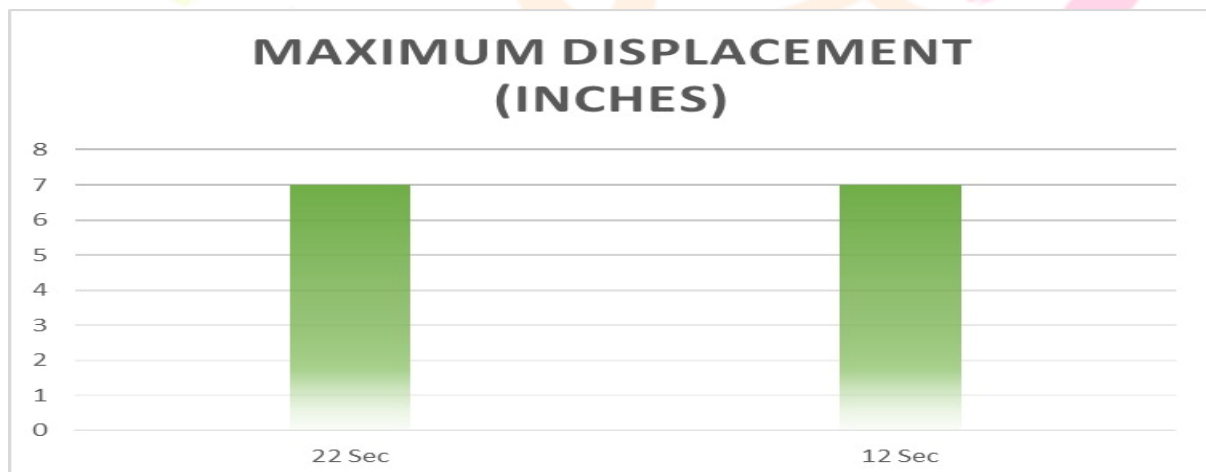

Figure 11: Performance of Transient Structural Analysis of Robotic Arm

5. Conclusion

This study presents a comprehensive transient structural analysis of a robotic arm, aimed at evaluating its dynamic response and structural integrity under time-dependent loading conditions. The analysis was performed for durations of 22 seconds and 12 seconds, revealing consistent maximum displacements of 7 inches without any structural failures in both scenarios. The robotic arm, featuring multiple joints, links, actuators, and sensors, was meticulously modeled using advanced CAD software to ensure precise geometrical representation and accurate material properties assignment. For both the 22-second and 12-second analyses, the maximum stress observed reached 1000 MPa, primarily concentrated at the joints and along the arm's length for the longer duration, and near the actuators for the shorter duration. The deformation patterns indicated a steady increase in displacement with minor oscillations, demonstrating dynamic but stable

behavior. The calculated safety factors, derived from the material's yield strength and observed stress levels, confirmed that the design was well within safe operating limits, highlighting the robustness of the robotic arm. The displacement versus time graph for both analyses displayed a typical transient response, with displacement increasing rapidly initially before stabilizing. This quasi-steady state behavior is crucial for understanding the arm's performance under sudden loads, ensuring its reliability in dynamic environments. The stress versus time graph showed an early peak followed by a plateau, consistent with the displacement behavior, further validating the arm's structural integrity.

References

1. AL-Awadhi, B. M. H. A., & Chauhan, N. (2024, January). Design and optimization of soft gripper for material handling using a robotic arm. In *AIP Conference Proceedings* (Vol. 2962, No. 1). AIP Publishing.
2. Alebooyeh, M., & Urbanic, J. (2024). Development of robotic automation solutions for limp flexible material handling leveraging a finite element modelling technique. *The International Journal of Advanced Manufacturing Technology*, 132(1), 781-800.
3. Sayadi, A., Cecere, R., & Hooshiar, A. (2024). Finite Arc Method: Fast-Solution Extended Piecewise Constant Curvature Model of Soft Robots with Large Variable Curvature Deformations. *Robotics Reports*, 2(1), 49-64.
4. Xian, C., Zhang, H., Kim, Y. C., Zhang, H., & Liu, Y. (2024). An Integrated System for Mechanical Fatigue Life Prediction via Multi-Body Dynamics and Finite Element Analysis: A Case Study on Excavator Turntables. *Heliyon*.
5. Ilunga, M., & Agarwal, A. (2024). A Finite-Element-Analysis-Based Feasibility Study for Optimizing Pantograph Performance Using Aluminum Metal Matrix Composites. *Processes*, 12(3), 445.
6. Zhou, S., Wu, H., Li, X., Li, B., Wang, Y., Guo, X., & Yang, G. (2024). Control of residual stress in inter-layer hammering hybrid arc-based directed energy deposition manufacturing of cross-structure based on finite element method. *Materials & Design*, 112721.
7. Zhong, J., Jiang, W., Zhang, Q., & Zhang, W. (2023, September). Design and Simulation of a Seven-Degree-of-Freedom Hydraulic Robot Arm. In *Actuators* (Vol. 12, No. 9, p. 362). MDPI.
8. Ferrentino, P., Roels, E., Brancart, J., Terryn, S., Van Assche, G., & Vanderborght, B. (2023). Finite element analysis-based soft robotic modeling: Simulating a soft actuator in sofa. *IEEE Robotics & Automation Magazine*.
9. Wandke, K. (2023). Physics-Based Finite Element Simulation of the Dynamics of Soft Robots. *IEEE Access*.
10. Zhang, Y., Chen, Y., Song, Y., Zhang, R., & Wang, X. (2023). Finding the lowest damage picking mode for tomatoes based on finite element analysis. *Computers and Electronics in Agriculture*, 204, 107536.
11. Shen, K. (2023, July). Static Analysis of Picking Bionic Robot Arm Based on ANSYS Workbench. In *2023 International Conference on Design Science (ICDS)* (pp. 1-5). IEEE.

12. Yao, X. (2023). Design and Fabrication of Robotic arm for Multiple Degrees of Freedom Control. *Science and Technology of Engineering, Chemistry and Environmental Protection*, 1(3).
13. Arun, V., & Prabhu, S. (2022). Design and vibration analysis on EMS by using Block Lanczos method for humanoid robotics arm applications. *International Journal on Interactive Design and Manufacturing (IJIDeM)*, 1-12.
14. Appadurai, M., & Fantin Irudaya Raj, E. (2021). Finite element analysis of lightweight robot fingers actuated by pneumatic pressure. In *Recent Advances in Manufacturing, Automation, Design and Energy Technologies: Proceedings from ICoFT 2020* (pp. 379-385). Singapore: Springer Singapore.
15. Daniyan, I., Mpofu, K., Ramatsetse, B., & Adeodu, A. (2020). Design and simulation of a robotic arm for manufacturing operations in the railcar industry. *Procedia Manufacturing*, 51, 67-72.
16. Ćurković, P., & Jambrečić, A. (2020). Improving structural design of soft actuators using finite element method analysis. *Interdisciplinary Description of Complex Systems: INDECS*, 18(4), 490-500.
17. Buffinton, K. W., Wheatley, B. B., Habibian, S., Shin, J., Cenci, B. H., & Christy, A. E. (2020, May). Investigating the mechanics of human-centered soft robotic actuators with finite element analysis. In *2020 3rd IEEE International Conference on Soft Robotics (RoboSoft)* (pp. 489-496). IEEE.
18. Shanmugasundar, G., Sivaramakrishnan, R., Meganathan, S., & Balasubramani, S. (2019). Structural optimization of an five degrees of freedom (T-3R-T) robot manipulator using finite element analysis. *Materials Today: Proceedings*, 16, 1325-1332.
19. Jain, R., Zafar, M. N., & Mohanta, J. C. (2019, November). Modeling and analysis of articulated robotic arm for material handling applications. In *IOP Conference Series: Materials Science and Engineering* (Vol. 691, No. 1, p. 012010). IOP Publishing.
20. Liu, Z., Song, L. B., Li, Y., & Pan, B. Z. (2017, May). Comparison of finite element and experimental modal analysis of multi-joint flexible robotic arm. In *2017 International Conference on Mechanical, System and Control Engineering (ICMSC)* (pp. 96-100). IEEE.
21. Elsayed, Y., Vincensi, A., Lekakou, C., Geng, T., Saaj, C. M., Ranzani, T., ... & Menciassi, A. (2014). Finite element analysis and design optimization of a pneumatically actuating silicone module for robotic surgery applications. *Soft Robotics*, 1(4), 255-262.
22. Kimura, H., Kataoka, M., Suzuki, S., Akimoto, D., & Inou, N. (2012). A flexible robotic arm with hydraulic skeleton. *Journal of advanced mechanical design, systems, and manufacturing*, 6(7), 1107-1120.