



Creating Cost-Effective Single Axis Laser Cutting Machine

¹Aymaan Ahmed, ²Elijah Lancelot, ³Hrudayash Acharekar,
⁴Kabir Ramteke, ⁵Priyanshu Wankhede, ⁶Preet Kelwadkar,
⁷Prof. Suhas Rewatkar

¹Student, ² Student, ³ Student, ⁴ Student, ⁵ Student, ⁶ Student, ⁷Professor

¹Department of Mechanical Engineering,

¹JD College of Engineering and Management, Nagpur, India.

Abstract : Laser-cutting technology has become one of the most advanced technologies. Laser-cutting machines play an important role not only in mechanical engineering but also in many other industries, including electronics manufacturing, garment manufacturing, and handicrafts. In this study, the design and manufacturing process of a Laser-cutting machine is proposed. The Laser-cutting machine should be planned and designed to be easy to install and operate, and the equipment cost should be low. This advanced single-axis Laser-cutting machine excels at carving wood to precise depths of 1 to 2 millimeters. Its cutting-edge features include an adaptive laser focusing system for consistent depth, high-precision thermal management to prevent distortion, and smart depth control algorithms for real-time adjustments. Enhanced with a user-friendly interface and eco-friendly operation, this machine offers exceptional accuracy and versatility, making it ideal for detailed designs and intricate woodwork., acrylic sheets ceramic materials. The recommended Laser-cutting machine model can cut at a speed of 1000mm/min, which meets your requirements.

IndexTerms - Lasers, Machining, Sensors, Motors.

I. INTRODUCTION

Laser-cutting machines play a significant role in solving the critical need to speed up the production process, leading to significant improvements in reliability and quality. From a scientific perspective, these machines are effective in solving manufacturing problems related to cutting and marking complex parts of various products of all sizes. In addition to traditional cutting methods such as milling and turning, Laser-cutting machines are also widely used in industries such as electronics, medical, aerospace, and automotive. Applications of these machines include cutting a variety of metals, including tungsten, aluminum, steel, brass, and nickel, acrylic, ceramic. Lasers are known for their ability to deliver precise cuts and complete end-to-end results. Lasers can also be used to cut ceramics, silicon and other metal films. Laser-cutting machine in Vietnam improves the company's automation ability by reducing the number of workers needed and reducing the interruption in the use of technology, thus reducing the number of workers Errors, lessons learned. The production and use of Laser-cutting face many limitations in production. Currently, most Laser-cutting machines are used by companies specializing in mass production and mold-making. In addition, these machines currently on the market are expensive and do not fit the income of most Vietnamese people. Laser cutters are rarely used in small shops and university laboratories. In response to current challenges, many companies and some universities are working on the development of Laser-cutting machines that can meet the needs of production and research. This paper presents a plan for the development and application of a cheap Laser-cutting machine that meets the basic requirements of production and marketing.

II. LITERATURE REVIEW

Laser-cutting has become a pivotal technology in modern manufacturing, driven by advancements in laser systems and process optimizations. This literature review synthesizes recent research on Laser-cutting technologies, focusing on innovations in laser systems, optimization techniques, and material considerations.

2.1 Technological Advancements in Laser-cutting Systems

Recent studies highlight the evolving landscape of Laser-cutting technologies, with a significant emphasis on the comparison of different laser systems. Saucedo et al. (2016) compare direct diode lasers with other laser systems, demonstrating that direct diode lasers offer advantages in terms of efficiency and cost-effectiveness for specific cutting applications [2]. This comparison is crucial for selecting the appropriate laser technology based on the desired application and material characteristics.

Gyasi et al. (2022) explore the integration of robot Laser-cutting systems within the Industry 4.0 framework. Their research emphasizes the role of automation and smart technologies in enhancing the precision and adaptability of Laser-cutting processes [1]. This integration signifies a significant step towards more efficient and flexible manufacturing systems.

2.2 Process Optimization and Quality Control

Optimization of Laser-cutting processes is critical for improving cut quality and efficiency. Struckmeier et al. (2020) focus on the use of laser triangulation to measure supporting slats in Laser-cutting machines, which is essential for ensuring consistent and high-quality cutting performance [3]. Accurate measurement of support structures can lead to better control over cutting parameters and improved product quality.

Genna et al. (2020) investigate the impact of material selection and process parameters on kerf quality during industrial Laser-cutting. Their experimental study highlights the importance of optimizing both material types and cutting parameters to achieve the desired cut quality [4]. This research provides valuable insights into the factors affecting kerf quality and offers guidance for process adjustments.

Sharifi and Akbari (2019) examine the effect of process parameters on the temperature and quality of cutting edges in AL6061T6 alloy. Their findings underscore the importance of managing thermal effects to maintain cutting precision and edge quality [5]. This research is particularly relevant for applications requiring high precision and durability.

2.3 Advanced Material Processing and Applications

The cutting of advanced materials presents unique challenges and opportunities. Vora et al. (2021) perform a Pareto optimization of fiber Laser-cutting processes for Ti6Al4V, a high-strength titanium alloy. Their study demonstrates the potential for optimizing Laser-cutting parameters to enhance process efficiency and material performance [7].

Ullah et al. (2022) investigate the energy efficiency and cut quality of fiber Laser-cutting on aluminum alloys under various hardened conditions. Their research shows that energy efficiency and cut quality can be significantly improved by optimizing process conditions for different material states [8].

Huang et al. (2023) explore multi-objective optimization of fiber Laser-cutting for glass fiber-reinforced plastic (GFRP) materials. Their study highlights the complexities involved in achieving high-quality cuts in composite materials, which often require balancing multiple quality characteristics [9].

2.4 Innovations in Hybrid Manufacturing Techniques

Recent innovations also include the integration of Laser-cutting with other manufacturing techniques. Petousis et al. (2023) investigate the use of CO₂ Laser-cutting in combination with material extrusion in 3D printing to create multifunctional PLA/CNTs nanocomposite structures. This hybrid approach opens new possibilities for producing complex geometries with enhanced material properties [10].

III. METHODOLOGY

Our research will utilize a comprehensive approach to understand the nuances of single-axis Laser-cutting. We will conduct a literature review of relevant academic journals and industry publications, analyzing existing research and technical papers. This will be complemented by interviews with industry experts, allowing us to gain insights into real-world applications, challenges, and future trends. We will also analyze market data and industry reports to understand the current state and future prospects of single-axis Laser-cutting.

To ensure a thorough understanding of the subject matter, we will delve into a comprehensive review of existing research and literature related to single-axis Laser-cutting. We will analyze published academic papers, industry articles, and relevant technical documents to glean insights into the historical development, current state, and future potential of this technology. By examining the findings and perspectives presented in these sources, we aim to develop a strong foundation for our analysis and understanding.

Furthermore, we will engage in direct discussions with key industry experts. Through these interviews, we will seek to gather valuable perspectives and insights from individuals with hands-on experience in the field. These conversations will shed light on real-world applications, challenges, and potential innovations that might not be readily available in published literature. By learning from those who are actively shaping the landscape of single-axis Laser-cutting, we will gain a deeper understanding of the practical implications and future trends in this technology.

To gain a comprehensive understanding of the market landscape and the future potential of single-axis Laser-cutting, we will analyze relevant market data and industry reports. This will involve examining information on the current market size, growth trends, key players, technological advancements, and emerging applications. By analyzing this data, we will gain insights into the factors driving demand, potential challenges, and future opportunities within this industry. This will provide a broader perspective on the role of single-axis Laser-cutting within the larger manufacturing ecosystem.

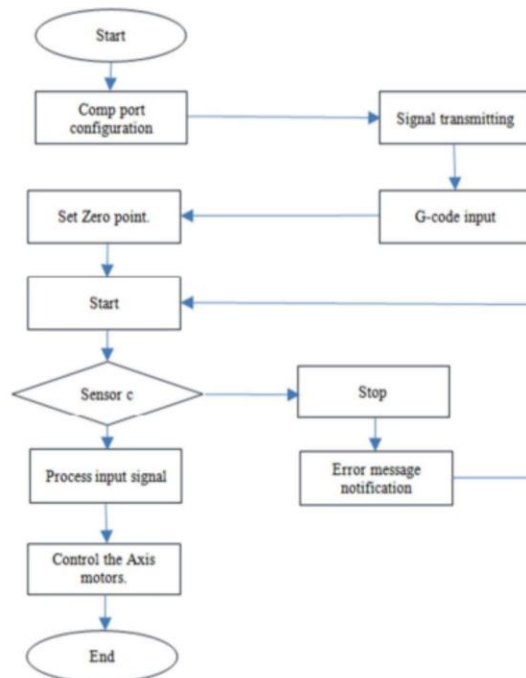

fig. system flow

IV. ANALYSIS

The Laser-cutting machine model represents the working principle of the CNC machine tool, which is controlled by special software and applied to the actual field. The Laser-cutting machine uses the energy generated by the laser to bring it to the surface of the material through the lens system of the machine. The machine can cut workpieces with a size of 250×250 mm. It has a cutting speed of 500 mm/min and can draw to a depth of less than 2 mm. The cutting job takes an average of 60 minutes to complete. Figure 1 shows the basic design and operating details of the prototype machine. First, the control software converts the loaded image into G-code for cutting. The motor (1) transfers motion to the assembly (4) that holds the laser diode by utilizing the lead screw and nut set (3). Consequently, the laser diode's axis (5) will align precisely with the X-coordinate currently indicated on the control software. The motor (2) transfers motion to the machine table (6) via the lead screw and the nut assembly (7). Thus, the laser diode's axis (5) will align with the Y coordinate of the current point indicated on the control software. Once the point coordinates are established, the laser diode (5) releases a laser beam. The beam possesses a significant amount of energy, enabling it to effectively heat the surface of the product at the specific point of focus. This, in turn, facilitates the material melting. The liquefied substance will be displaced from its initial location by a forceful flow of gas that is aligned with the laser beam. The molten region will persistently undergo elongation along the trajectory of the laser beam, resulting in a cleave and the formation of the desired shape.

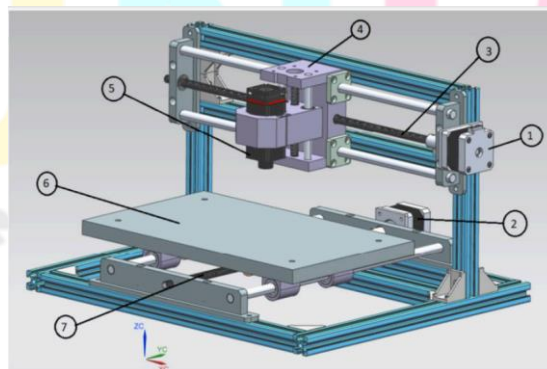

fig. machine model

V. CONCLUSION

This article presents a method for developing and manufacturing Laser-cutting machine prototypes, including calculation, design, simulation and manufacturing stages. Test results show that the machine completes the basic tasks. The machine has a small size of $400 \times 330 \times 250$ mm and can cut workpieces with a length of 300×250 mm with a maximum cutting depth of 2 mm. Compared with similar products, the manufacturing cost of this machine is relatively cheap.

VI. REFERENCE

- [1] E. A. Gyasi, A. Antila, P. Owusu-Ansah, P. Kah, and A. Salminen, "Prospects of Robot Laser-cutting in the Era of Industry 4.0," *World Journal of Engineering and Technology*, vol. 10, no. 3, pp. 639–655, Jul. 2022, <https://doi.org/10.4236/wjet.2022.103042>.
- [2] F. V. Saucedo, B. Chann, B. Samson, and P. Tayebati, "Direct diode vs. other laser systems used in Laser-cutting," *Laser Focus World*, Mar. 16, 2016. <https://www.laserfocusworld.com/industrial-laser-solutions/article/14216486/direct-diode-vs-other-laser-systems-used-in-lasercutting>.
- [3] F. Struckmeier, J. Zhao, and F. P. León, "Measuring the supporting slats of Laser-cutting machines using laser triangulation," *The International Journal of Advanced Manufacturing Technology*, vol. 108, no. 11, pp. 3819–3833, Jun. 2020.
- [4] S. Genna, E. Menna, G. Rubino, and V. Tagliaferri, "Experimental Investigation of Industrial Laser-cutting: The Effect of the Material Selection and the Process Parameters on the Kerf Quality," *Applied Sciences*, vol. 10, no. 14, Jan. 2020, Art. no. 4956.
- [5] M. Sharifi and M. Akbari, "Experimental investigation of the effect of process parameters on cutting region temperature and cutting edge quality in Laser-cutting of AL6061T6 alloy," *Optik*, vol. 184, pp. 457–463, May 2019, <https://doi.org/10.1016/j.jjleo.2019.04.105>.
- [6] A. E. Gvozdev et al., "Multiparametric optimization of Laser-cutting of steel sheets," *Inorganic Materials: Applied Research*, vol. 6, no. 4, pp. 305–310, Jul. 2015.
- [7] J. Vora et al., "Experimental Investigations and Pareto Optimization of Fiber Laser-cutting Process of Ti6Al4V," *Metals*, vol. 11, no. 9, Sep. Art. no. 1461, 2021.
- [8] S. Ullah et al., "Energy efficiency and cut-quality improvement during fiber Laser-cutting of aluminum alloy in the different hardened conditions," *Materials Today Communications*, vol. 33, Dec. 2022, Art. no. 104236, <https://doi.org/10.1016/j.mtcomm.2022.104236>.
- [9] S. Huang, Z. Fu, C. Liu, and J. Li, "Multi-objective optimization of fiber Laser-cutting quality characteristics of glass fiber reinforced plastic (GFRP) materials," *Optics & Laser Technology*, vol. 167, Dec. 2023, Art. no. 109720, <https://doi.org/10.1016/j.optlastec.2023.109720>.
- [10] M. Petousis, K. Ninikas, N. Vidakis, N. Mountakis, and J. D. Kechagias, "Multifunctional PLA/CNTs nanocomposites hybrid 3D printing integrating material extrusion and CO2 Laser-cutting," *Journal of Manufacturing Processes*, vol. 86, pp. 237–252, Jan. 2023.

