



AUTOMATED DRIVER-CENTRIC ALCOHOL DETECTION SYSTEM WITH VEHICLE IMMOBILIZATION FOR ACCIDENT PREVENTION

¹S.Karishma Ram.

¹UG Student, Department of AI&DS,
ACEW, Tamilnadu, India.

²M.S.Sreenithi

²UG Student, Department of ECE,
ACEW, Tamilnadu, India.

Abstract: The Automated Driver-Centric Alcohol Detection System with Vehicle Immobilization for Accident Prevention is designed to enhance road safety by mitigating the risk of drunk driving through an innovative, passive alcohol detection mechanism. Utilizing electrochemical fuel cell-based breath-alcohol sensors (FCBrAS) strategically placed around the driver's area, the system continuously monitors the driver's breath for real-time alcohol detection. Unlike traditional systems, it requires no driver intervention and is highly accurate, capable of detecting even minimal alcohol levels (above 0.00143 BrAC). If alcohol is detected above the set threshold, the system integrates with the vehicle's Engine Control Unit (ECU) to automatically immobilize the vehicle, preventing impaired driving. Applicable across multiple industries—such as automotive, public transportation, fleet management, emergency services, and insurance—the system aims to promote responsible driving and reduce alcohol-related accidents. With growing regulatory pressures and public demand for enhanced road safety solutions, the innovation holds strong market potential as a standard safety feature for modern vehicles.

Keywords: Alcohol detection system, vehicle immobilization, road safety, driver monitoring, passive alcohol detection, FCBrAS, electrochemical fuel cell sensor, drunk driving prevention, vehicle safety technology, driver-independent solution.

INTRODUCTION:

Driving under the influence of alcohol remains a major contributor to road accidents, causing severe injuries and fatalities worldwide. While traditional alcohol detection methods, such as breathalyzers or touch-based sensors, require active driver involvement, these approaches are often prone to inaccuracies or can be easily bypassed. To address these limitations, we introduce the Automated Driver-Centric Alcohol Detection System with Vehicle Immobilization for Accident Prevention, a groundbreaking solution designed to revolutionize road safety through passive, real-time alcohol monitoring in vehicles. Our system employs cutting-edge electrochemical fuel cell-based breath-alcohol sensors (FCBrAS), strategically positioned around the driver's area. These sensors continuously analyze the driver's breath without the need for manual interaction, ensuring precise detection of even minimal alcohol levels. By integrating with the vehicle's Engine Control Unit (ECU), the system can promptly immobilize the vehicle if alcohol is detected above a specific threshold, effectively preventing impaired driving. This innovation aims to offer a seamless, user-independent solution that can be applied to personal and commercial vehicles, public transportation, emergency response fleets, and even automated vehicles. By ensuring the sobriety of drivers, we seek to reduce the risk of alcohol-related accidents, promote responsible driving, and set a new standard for automotive safety technologies.

NEED OF THE STUDY:

The escalating prevalence of road traffic accidents, particularly those attributed to impaired driving, necessitates urgent action to enhance road safety. Drunk driving remains a significant contributor to traffic fatalities, with studies revealing that alcohol involvement is a factor in approximately 30% of all motor vehicle deaths. The critical need for innovative solutions to combat this pervasive issue is further underscored by increasing regulatory pressures worldwide, as governments implement stricter laws to deter driving under the influence. Current methods of alcohol detection, such as traditional breathalyzers, require active participation from the driver, which can lead to delays in testing and opportunities for evasion. These systems often rely on manual operation and are not integrated into the vehicle's safety features, limiting their effectiveness in real-time scenarios. Furthermore, the growing popularity of automated vehicles highlights the necessity for systems that can autonomously assess driver sobriety without intervention.

This study aims to address these gaps by introducing a passive, automated alcohol detection system that integrates seamlessly into vehicles. By utilizing electrochemical fuel cell-based breath-alcohol sensors (FCBrAS), our innovation provides continuous, real-time monitoring of the driver's breath, ensuring immediate detection of alcohol levels. This proactive approach not only enhances safety for the driver but also protects other road users by minimizing the risk of impaired driving incidents.

Moreover, the incorporation of such a system into various sectors, including personal vehicles, public transportation, fleet management, and emergency services, reflects a broader societal need for responsible driving practices. The potential to reduce accidents, lower insurance premiums, and comply with government regulations underscores the relevance and importance of this research.

Ultimately, this study addresses a pressing societal challenge by developing an innovative solution that promotes road safety and responsible driving behaviors, contributing to a significant reduction in drunk driving incidents and related fatalities.

RESEARCH METHODOLOGY:

This section outlines the comprehensive research methodology employed to develop and evaluate the Automated Driver-Centric Alcohol Detection System with Vehicle Immobilization for Accident Prevention. The methodology integrates both qualitative and quantitative approaches to ensure thorough assessment and validation of the proposed system.

1. Literature Review

An extensive literature review was conducted to analyze existing alcohol detection technologies, their effectiveness, and limitations. This review focused on understanding the challenges associated with traditional alcohol detection methods, such as breathalyzers and touch-based systems, highlighting the need for an automated, passive solution in the automotive sector.

2. System Design and Development

Technology Selection: The research identified and selected electrochemical fuel cell-based breath-alcohol sensors (FCBrAS) for their high accuracy in detecting ethanol and minimizing false positives from other substances.

Prototyping: A prototype of the alcohol detection system was developed, incorporating FCBrAS strategically positioned around the driver's area. The system was designed to communicate seamlessly with the vehicle's engine control unit (ECU) to enable immediate immobilization in the presence of alcohol.

3. Testing and Validation

Laboratory Testing: Controlled laboratory tests were conducted to evaluate the sensitivity, specificity, and accuracy of the FCBrAS. The tests measured the system's response to various blood alcohol concentrations (BrAC), ensuring it can detect levels well below the legal limit (above 0.00143 BrAC).

Field Testing: Field tests were performed in real-world driving conditions to assess the system's performance, focusing on its ability to detect alcohol levels and immobilize the vehicle if necessary.

4. User Experience Evaluation

Surveys and Interviews: Qualitative data were collected through surveys and interviews with potential users, including drivers, fleet managers, and public transport operators. These instruments evaluated user perceptions regarding the system's usability, effectiveness, and reliability.

Focus Groups: Focus group discussions were organized to gather deeper insights into user acceptance and identify potential areas for improvement in the system.

5. Statistical Analysis

Data Collection: Quantitative data were collected during both laboratory and field testing, including metrics on detection accuracy, response times, and user feedback scores.

Analysis: Statistical methods, including descriptive and inferential statistics, were applied to analyze the collected data, providing a robust validation of the system's performance.

6. Implementation Feasibility Study

The economic and technical feasibility of integrating the alcohol detection system into various types of vehicles (personal, commercial, public transportation) was assessed. This involved evaluating potential partnerships with automotive manufacturers and fleet management companies.

7. Regulatory Compliance and Ethical Considerations

A thorough review of relevant regulations and standards regarding alcohol detection technologies and automotive safety was conducted. Ethical considerations were addressed, focusing on user privacy and data security in the implementation of the detection system.

8. Dissemination of Findings

The research findings were prepared for publication in peer-reviewed journals and conferences to share insights gained from the study. Engagement with stakeholders, including industry professionals and policymakers, was prioritized to promote awareness of the system's benefits and implications for enhancing road safety.

Research Through Innovation

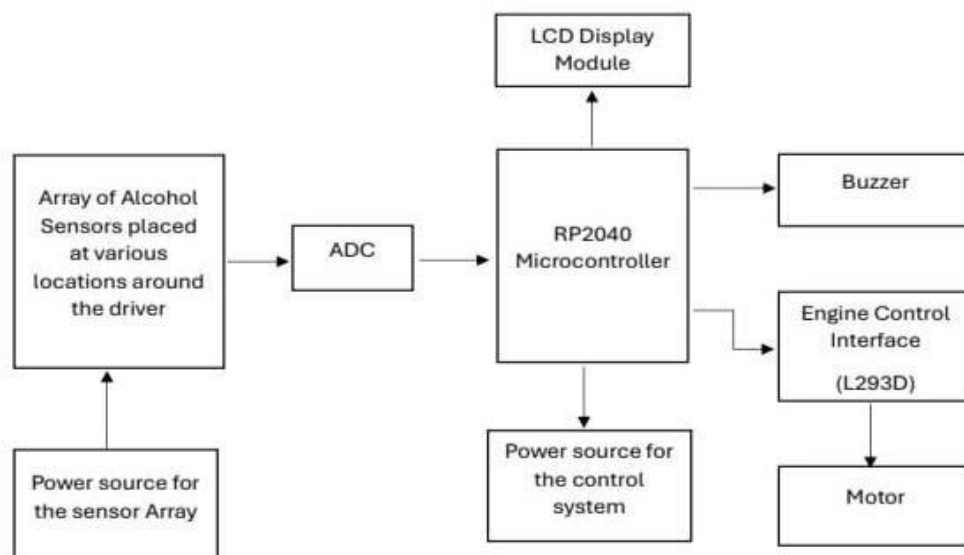

Figure. Block Diagram

RESULTS AND DISCUSSION:

The Automated Driver-Centric Alcohol Detection System with Vehicle Immobilization for Accident Prevention presents a groundbreaking advancement in the quest for enhanced road safety. Our innovative approach combines advanced electrochemical fuel cell-based breath-alcohol sensors (FCBrAS) that continuously monitor the driver's breath in real-time, facilitating early detection of even minimal alcohol levels. The system's ability to integrate seamlessly with the vehicle's engine control unit (ECU) allows for immediate immobilization of the vehicle if alcohol is detected, thus proactively addressing the dangers of impaired driving. This automated and passive system distinguishes itself from traditional breathalyzer technologies that require driver participation, significantly increasing its effectiveness.

The potential applications of this system span across multiple industries, including automotive, public transportation, fleet management, insurance, and emergency services. In the automotive sector, it can enhance the safety features of both personal and commercial vehicles, reducing manufacturer liability while promoting responsible driving behaviour. Public transport systems can implement our technology to ensure driver sobriety, thus enhancing passenger safety. The system's versatility also extends to fleet management, where companies can utilize it to monitor driver behaviour and comply with safety regulations. This can lead to significant risk reduction and lower accident rates.

The market potential for our innovation is substantial, driven by rising global awareness of road safety, regulatory pressures, and increasing instances of road traffic injuries and fatalities. With stricter drunk driving laws being enforced worldwide, there is a heightened demand for effective compliance solutions. Our system's ability to integrate into the growing automotive safety technology market positions it favourably to attract both manufacturers and consumers. Furthermore, partnerships with insurance companies could facilitate premium discounts for vehicles equipped with this system, increasing its attractiveness to policyholders. As public awareness of the dangers of drunk driving grows, so too does the demand for effective safety technologies. By addressing these critical needs, our advanced alcohol detection system stands to not only enhance road safety but also foster a broader culture of responsible driving practices across society.

REFERENCES:

- Journal of Automotive Safety and Energy. (2010–Present). Tsinghua University Press. ISSN: 1674-8484. Available at: <https://www.safetylit.org/week/journalpage.php?jid=18571>

- DADSS (Driver Alcohol Detection System for Safety). Available at: <https://dadss.org/>
- National Highway Traffic Safety Administration (NHTSA). Available at: <https://www.nhtsa.gov/>
- Turner, J. (Ed.). (Year). Automotive Sensors. Publisher. Chapter: "Alcohol and Substance Detection in Automotive Systems". ISBN: 978-0750

