



HIGH-GAIN Z-SOURCE CONVERTER FOR PV-DRIVEN EV MOTOR USING DOLPHIN POD-OPTIMIZED PI CONTROLLER

¹B. Vinod Kumar, ²A. Venkata Mani Govindu, ³Kakana Boyina Rohit, ⁴Dr. B. Kavya Santhoshi

¹UG Student, ²UG Student, ³UG Student, ⁴Assistant Professor

^{1,2,3,4}Department of Electrical and Electronics Engineering,

^{1,2,3,4}Godavari Institute of Engineering and Technology (Autonomous), Rajahmundry, A.P., India.

Abstract: The integration of photovoltaic (PV) energy into electric vehicle (EV) systems offers a sustainable alternative to traditional fossil-fuel-based power sources. Conventional Proportional-Integral (PI) controllers are widely used for EV motor control but often struggle with non-linearities, parameter variations, and system uncertainties, leading to suboptimal performance. To address these challenges, this project proposes an advanced control strategy for a renewable energy system that integrates a PV source with a high-gain switched quasi Z-source converter and a bidirectional DC-DC converter. This system efficiently manages energy flow between the PV source, battery storage, and power loads, including a Permanent Magnet Synchronous Motor (PMSM) for EV applications. The proposed architecture employs Pulse Width Modulation (PWM) techniques for precise voltage regulation, utilizing an improved Dolphin POD-optimized PI controller. This controller stabilizes both the DC bus and battery voltage, enhancing overall system performance. Additionally, the system incorporates three-phase and single-phase voltage source inverters (VSIs) to ensure efficient power distribution to the EV load and grid. By maximizing energy utilization, improving response times, and maintaining system stability under varying operational conditions, this approach contributes to more efficient and sustainable EV energy solutions. The proposed system is implemented and analyzed using MATLAB 2021a Simulink.

Index Terms – Photo Voltaic (PV); Electric Vehicle (EV); Permanent Magnet Synchronous Motor (PMSM); Pulse Width Modulation (PWM)

I. INTRODUCTION

As the world transitions toward renewable energy, photovoltaic (PV) systems have become a crucial component of modern power grids, offering a clean and sustainable alternative to fossil fuel-based electricity generation. By leveraging semiconductor technology, PV systems directly convert sunlight into electricity. However, their large-scale deployment presents challenges that must be addressed to ensure grid stability, reliability, and efficiency.

One of the primary challenges in PV grid integration is the intermittent nature of solar energy. Unlike conventional power plants that provide electricity on demand, solar energy generation fluctuates based on weather conditions and sunlight availability. This variability can impact grid stability, necessitating advanced management strategies to balance supply and demand effectively. Grid-tied inverters play a vital role in this process by converting the DC output of solar panels into grid-compatible AC power, ensuring efficient energy transmission.

Energy storage technologies, such as batteries, are essential for stabilizing PV grid integration. These systems store excess solar energy generated during peak sunlight hours and release it when production declines or demand surges, thereby preventing power fluctuations and improving grid reliability. Additionally, real-time monitoring and adaptive energy management strategies help optimize solar power utilization by aligning consumption with peak production periods.

Another critical aspect of PV grid integration is the deployment of smart grid technologies. These digital systems enhance operational efficiency and flexibility by enabling real-time electricity monitoring and automated control. Accurate solar energy forecasting methods are also necessary to improve prediction accuracy and facilitate better power distribution planning. Grid operators must proactively address potential failures, particularly in regions where PV systems contribute significantly to energy supply.

As PV adoption continues to expand, infrastructure development and strategic planning are essential to prevent transmission bottlenecks and enhance grid security. Policymakers and energy regulators play a crucial role in supporting PV integration by promoting energy storage solutions, investing in grid upgrades, and establishing clear regulatory frameworks for PV system connections.

The integration of PV systems into the electricity grid is a complex process that requires technological innovation, strategic management, and policy support. Successfully incorporating solar energy not only advances renewable energy targets but also reduces carbon emissions, strengthens energy security, and contributes to a sustainable energy future. As PV technology, storage solutions, and grid management continue to evolve, the role of solar energy in the global power landscape is set to grow significantly in the coming years.

II. LITERATURE SURVEY

Chang-Hua Lin et al [2024] introduced A non-isolated, disconnected, inductor-based, high gain DC-DC boost converter designed for renewable energy applications, particularly solar photovoltaic (PV) and fuel cell systems. The converter concept effectively maximizes the efficiency of low voltage DC power sources from power supplies by achieving high voltage gain in the circuit with low stress on the power control switch [1].

Krzysztof Tomczuk et al [2024] explored the decarbonization of heating systems, focusing on improving energy performance and efficiency in buildings, particularly through the integration of heat pumps and photovoltaic (PV) systems. They highlighted the EU directives driving the replacement of high-emission fossil fuel-based heating systems with emission-free alternatives [2].

Guosheng Tian et al [2024] introduced Isolated high-voltage soft-switching DC-DC converter designed for DC microgrid applications. This converter has two-switch quasi-z position network, a voltage multiplier unit and a transformer, has the advantages of high voltage gain, switching zero voltage switching (ZVS), zero voltage zero current switching (ZVZCS), and so on. It is used to turn on and off diodes and low voltage devices [3].

Ali Naqvi et al [2024] proposed a Multi-objective optimization and optimization using non-variable variables are used to improve PID controller tuning of brushless DC (BLDC) motors in electric vehicles (EVs). These motors are important for good performance, reliable speed, and tuning of PID controller is important for the car to be efficient and energy efficient. This paper shows the limitations of PID controller methods such as Ziegler-Nichols method that can provide the best performance in a wide research area [4].

Krishnan Selvaraj et al [2024] propose a solution uses a Gamma Z-source inverter (GZSI) combined with a high-gain secondary control (QBC) to control induction motor drives (AMDs). The higher voltage gain of the QBC and GZSI reduces the need for voltage scaling of photovoltaic (PV) systems, while reducing the output voltage of the QBC increases the performance of AMD systems. The PV-QBC-GZSI-AMD system concept is designed to control high-speed motors for applications requiring high-speed operation [5].

Rasha Kassem et al [2024] presented a new soft-switching (SS) multiphase interval boost converter (MIBC), consisting of three boost converters (BCs), is designed to charge lithium-ion batteries for photovoltaic (PV) power system applications. The converter concept works with two power converters, namely zero-current converter (ZCS) and zero-voltage converter (ZVS), during turn-off, thereby reducing the conversion ratio and improving the transfer efficiency (SF) [6].

E. Giglio et al [2023] explored the integration of storage and reserve requirements in the planning of off-grid micro grids, focusing on non-interconnected Mediterranean islands. They highlighted the importance of developing an accurate cost and unit commitment model for fuel-fired generators and addressed the formalization of power reserve requirements [7].

Amir Ahmadifar et al [2023] developed Energy Management Systems (EMS) for Renewable Energy Communities (RECs) whose main objective is to balance load and generation. To solve the problems caused by the lack of measurement and historical data and the impact of renewable energy, this paper proposed an optimization policy for REC. This study highlights the critical uncertainty problem caused by insufficient data and variability of renewable energy sources, which is often not addressed by existing EMS data and may affect REC management [8].

D. Ismail M. Ali et al [2023] propose a Enhanced Perturbation Observation (MPO) Maximum Power Point Tracking (MPPT) algorithm is designed to improve the performance of solar photovoltaic (PV) systems. The MPO algorithm improves the traditional MPPT method by dividing the power-voltage curve into four functional regions based on the estimated open circuit voltage [9].

Ataollah Samadian et al [2023] introduced a new type of ground fault semi-Z source DC-DC converter that adds an additional switch and diode compared to the traditional semi-Z source converter. The converter concept has several advantages, including the use of coupled inductors and transformers, which allow the power supply to support a small, low-voltage circuit with less stress on electronic devices and DC devices such as switches and diodes [10].

III. SYSTEM DESCRIPTION

The integration of photovoltaic (PV) energy into electric vehicle (EV) motor systems is transforming the transportation sector, promoting sustainability and energy efficiency. As the demand for clean energy solutions grows, PV-powered EVs provide a significant advantage by reducing dependence on fossil fuels and external charging infrastructure. By harnessing solar energy, these vehicles minimize environmental impact, offering a cleaner and more sustainable mode of transportation.

A PV-energized EV motor system, when equipped with an advanced control strategy, ensures optimal utilization of solar power while maintaining smooth and efficient vehicle operation. One such advanced mechanism is the Improved Dolphin Pod Optimized

PI Controller, specifically designed to manage the complexities and dynamic behavior of an EV motor system, which experiences variations in load, speed, and torque.

The Proportional-Integral (PI) controller plays a crucial role in real-time motor output adjustment, ensuring stable performance across varying driving conditions. The Improved Dolphin Pod optimization technique enhances the PI controller by refining its dynamic response, improving precision, and reducing system errors. By minimizing response time and maintaining accurate control over motor performance, this optimization significantly improves energy efficiency, ensuring that the vehicle operates at peak performance.

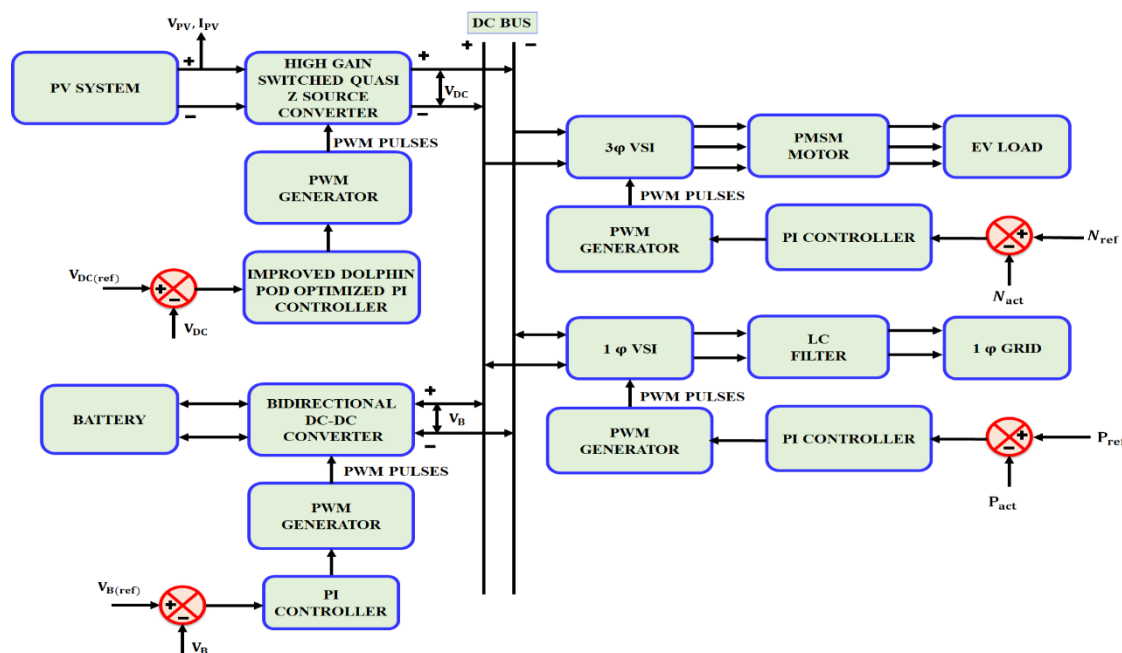

Figure 1 Block Diagram of Proposed System

A. PV System

In this energy system, designed to harness solar energy and convert it into usable electricity, photovoltaic (PV) technology serves as the primary renewable energy source. The process is driven by the photovoltaic effect, where solar radiation interacts with semiconductor materials in the solar panels, generating an electric current. A typical PV system consists of solar panels arranged in an array, a Maximum Power Point Tracking (MPPT) system to enhance energy output, and an integration mechanism for efficient power management.

Each solar panel is composed of photovoltaic cells, typically made of silicon, that absorb photons from sunlight. When sunlight strikes these cells, electrons are excited, creating electron-hole pairs that move through the material, producing direct current (DC). This DC power can be used directly or further processed for specific applications. The efficiency of the PV system depends on factors such as the quality of the semiconductor material, the panel's alignment with the sun, ambient temperature, and the level of solar irradiance.

One of the key challenges in PV energy generation is the variability of power output due to its dependence on sunlight. Solar energy production fluctuates throughout the day and is significantly influenced by weather conditions. Cloudy weather can reduce irradiance, leading to lower power output, while temperature variations can impact cell efficiency, often causing decreased performance under extreme heat. To ensure reliable and consistent energy production, system design must incorporate strategies to manage these fluctuations effectively.

To address these challenges, the PV system in this configuration is integrated with a high-gain switched quasi-Z source converter, which processes the raw DC power generated by the panels. This integration plays a crucial role in maintaining a stable output voltage despite fluctuations in solar irradiance and temperature. By optimizing PV system performance, this architecture enhances the efficiency and reliability of renewable energy utilization within the broader energy management system. Beyond its technical advantages, PV technology significantly contributes to environmental sustainability by reducing dependence on fossil fuels and lowering carbon emissions.

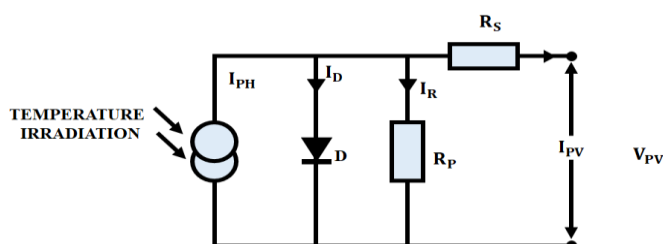

Figure 2 PV System Circuit Diagram

B. High-Gain Switched Quasi-Z Source Converter

The High-Gain Switched Quasi-Z Source Converter (HG-SQZSC) is a crucial component in power management, designed to optimize the utilization of electricity generated by photovoltaic (PV) systems. This converter effectively regulates the variable and often inconsistent DC output from PV panels, ensuring a stable and controllable DC voltage for the DC bus. By achieving a high voltage gain, it enhances the efficiency of power conversion and facilitates the seamless integration of renewable energy into the system. The HG-SQZSC integrates elements of a half-Z quasi-Z source converter (QZSC) with an advanced switching mechanism, enabling higher voltage conversion while minimizing short-circuit effects and power disruptions.

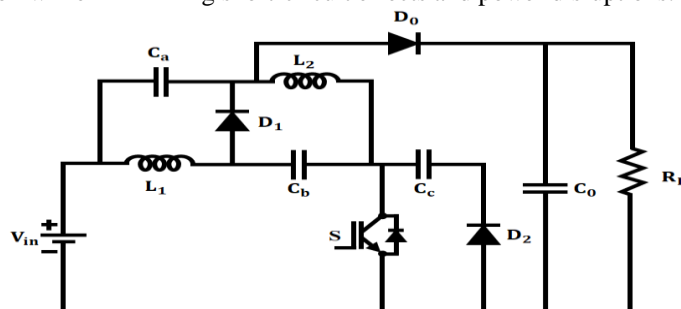

Figure 3 High Gain Switched Quasi ZSC

Mode 1 : Here, Switch S is kept ON along with Diode D0, Whereas, diodes D1 and D2 are turned OFF due to the reverse parallel connection. The inductor L1 gets charged via input Vi and capacitor C3 similarly, the inductor L2 gets charged using Vi and C1 respectively. Thus, making the capacitors C1 and C2 series to Vi.

Mode 2: In this mode of operation, switch S is turned OFF along with diode D0, whereas, the diodes D1 and D2 are turned ON. Here, inductor L1 gets charged through capacitor C1 and L2 gets charged via C3, thus making Vi and L1 series connection

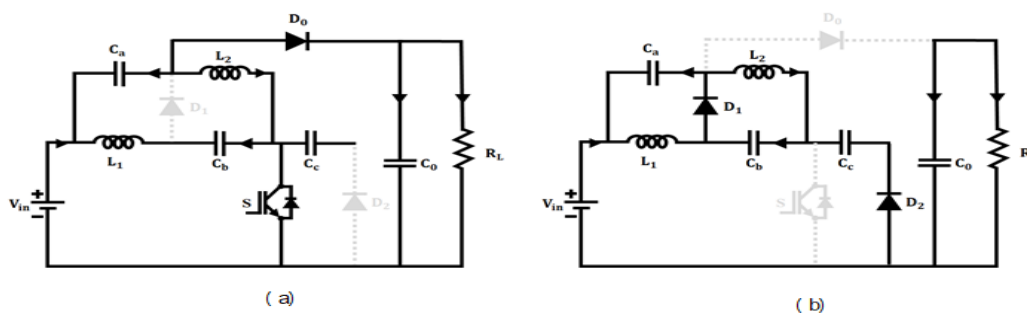

Figure 4 Converter Modes of Operation

C. Improved Dolphin POD Optimized PI Controller

The Improved Dolphin POD (Population-Oriented Differential Evolution) Optimized PI Controller is an advanced control mechanism designed to enhance the performance of energy management systems. It plays a crucial role in maintaining the stability and consistency of the output voltage in high-gain switched quasi-Z source converters, even under fluctuating input conditions such as varying solar irradiance or load demands. By employing nature-inspired optimization techniques, this controller ensures precise and adaptive control, significantly improving system efficiency and reliability.

At its core, the PI (Proportional-Integral) controller is a well-established strategy in industrial and power systems, valued for its simplicity and effectiveness. The proportional component provides immediate corrective action in response to error signals, while the integral component eliminates steady-state errors by accounting for accumulated past errors. However, conventional PI controllers often struggle in dynamic environments, such as renewable energy systems, where rapid input variations require highly adaptive control strategies.

This is where the Dolphin POD optimization technique comes into play. Inspired by the intelligent and cooperative foraging behaviors of dolphins, this algorithm dynamically adjusts the proportional and integral gains of the PI controller to achieve optimal performance under varying conditions. Dolphins employ a blend of exploratory and exploitative strategies to locate prey efficiently—principles that the Dolphin POD algorithm adapts to enhance controller tuning, ensuring robust and responsive system behavior.

D. PWM Generator

The Pulse Width Modulation (PWM) Generator is a critical component of the energy management system, responsible for converting control signals from various controllers—such as the Improved Dolphin POD Optimized PI Controller—into switching pulses for power electronic devices. These pulses regulate converter operations, ensuring precise energy flow and optimal system performance. Within the architecture of high-gain switched quasi-Z source converters, bidirectional DC-DC converters, and voltage source inverters (VSI), the PWM generator acts as the interface between control algorithms and power electronics, making it an indispensable part of the system.

Pulse Width Modulation is a widely used technique for controlling power delivery to electrical loads by adjusting the duty cycle of a signal. The duty cycle represents the ratio of the signals "on" time to its total period. By varying this ratio, the PWM generator effectively controls the average voltage and current supplied to the load. This approach enhances efficiency by minimizing switching energy losses while enabling precise regulation of power electronics, which is crucial for applications such as renewable energy systems and electric vehicles. Additionally, the PWM generator plays a vital role in controlling voltage source inverters (VSI) connected to both the Permanent Magnet Synchronous Motor (PMSM) and the grid. For a three-phase VSI driving a PMSM, the PWM generator ensures precise motor control by modulating the inverter switches based on inputs from the motor control block. This modulation enables the inverter to generate a three-phase AC output with the required frequency and amplitude, ensuring efficient motor operation under varying load conditions.

E. Bidirectional DC-DC Converter

Bidirectional DC-DC converters play a crucial role in electric power systems, enabling efficient conversion between two DC power sources. Their ability to operate in both directions makes them highly valuable in applications such as battery charging and discharging, renewable energy systems, electric vehicles (EVs), and energy storage systems (ESS). Unlike traditional unidirectional converters that allow power transfer in only one direction, bidirectional converters offer flexibility by enabling power flow in both directions as needed. This capability is particularly important in systems requiring energy storage and retrieval, such as hybrid or electric vehicles, where the battery must supply power to the motor and also recover energy through regenerative braking.

Bidirectional DC-DC converters function in two primary modes: buck mode and boost mode. In buck mode, the converter steps down a higher supply voltage to a lower level suitable for the load. In boost mode, the converter steps up a lower supply voltage to a higher level. This dual functionality is essential in applications like battery management, where controlled bidirectional energy flow helps maintain the state of charge (SOC) and improves battery performance.

Efficiency is a critical factor in bidirectional converters, as energy losses can significantly impact overall system performance, especially in large-scale applications like renewable energy plants and EV powertrains. To enhance efficiency, advanced control strategies such as duty cycle modulation and phase-shift modulation are employed. Furthermore, the selection of key components including inductors, capacitors, and switches must align with the power and voltage requirements of the application. The choice of these components directly influences the converter's efficiency, reliability, and response time. By optimizing control techniques and component selection, bidirectional DC-DC converters provide high-efficiency power conversion, ensuring stable and reliable energy management in modern electrical systems.

F. Three Phase VSI

A three-phase voltage source inverter (VSI) is an electronic device that converts direct current (DC) into three-phase alternating current (AC). This conversion is essential for various applications, including motor drives, renewable energy systems, uninterruptible power supplies (UPS), and photovoltaic (PV) system inverters. A three-phase VSI is designed to generate AC voltage with a controlled amplitude and frequency, making it suitable for driving three-phase induction motors or supplying power to the grid in power generation systems.

The operation of a three-phase VSI is based on the controlled switching of semiconductor devices such as insulated gate bipolar transistors (IGBTs), metal-oxide-semiconductor field-effect transistors (MOSFETs), or silicon carbide (SiC) devices. These switches are carefully managed to produce a sinusoidal AC output from the DC input. The inverter consists of three branches, each corresponding to one phase of the AC output. The DC power supply is connected to a three-phase bridge converter, typically configured as a full-bridge circuit with four switches per bridge. Sequential switching of these devices ensures the generation of a three-phase AC output.

Two primary techniques are used to control the switching in VSIs: pulse-width modulation (PWM) and space vector modulation (SVM). PWM is the most widely used method, as it allows precise voltage control and minimizes harmonic distortion. By adjusting the pulse width of each switch, the inverter can regulate the output voltage and frequency, providing flexibility for different applications. SVM, on the other hand, offers a more sophisticated and efficient control method, making it particularly useful in high-performance applications where precise voltage regulation and reduced switching losses are critical.

G. PMSM Motor

A permanent magnet synchronous motor (PMSM) is an electric machine that utilizes permanent magnets in the rotor to generate a fixed magnetic field. It is classified as a synchronous motor because the rotor spins at the same speed as the stator's magnetic field. PMSMs are widely used in applications that demand high efficiency, precise control, and high torque. Due to their superior efficiency compared to induction motors, they are commonly found in electric vehicles (EVs), robotics, HVAC systems, and industrial machinery. The use of permanent magnets in the rotor eliminates the need for external excitation, resulting in improved performance and energy savings.

V. RESULTS AND DISCUSSIONS

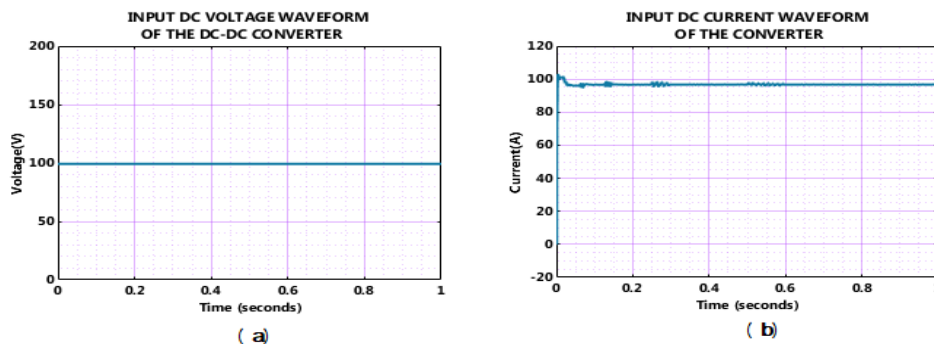

Figure 4.1 Input DC voltage and current Waveform

Figure 4.1 indicates input DC voltage and Input DC current, the first graph shows that, input voltage is maintained at 100V for the entire depicted time and the second graph shows that, input current is also maintained at 100 through the given time period, indicating improved system stability with increased power reliability.

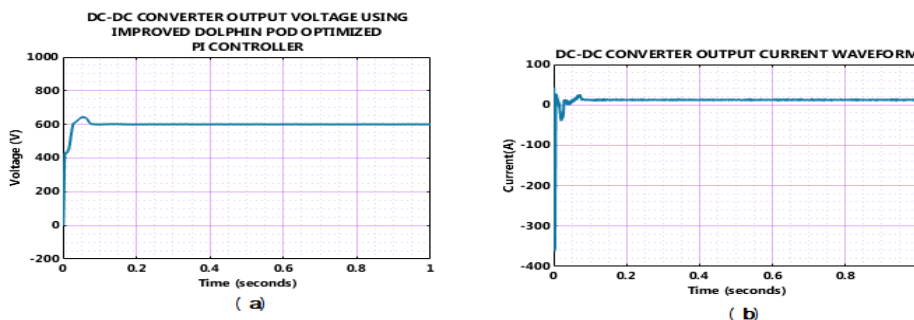

Figure 4.2 Output DC-DC converter voltage and current waveform

Figure 4.2 implies DC-DC output voltage, which initially deviates, after 0.1 seconds stabilizes and remains fixed at 600 V. Similarly, in Figure 4.2(b), output current also initially fluctuates and then stabilizes after 0.1 seconds respectively.

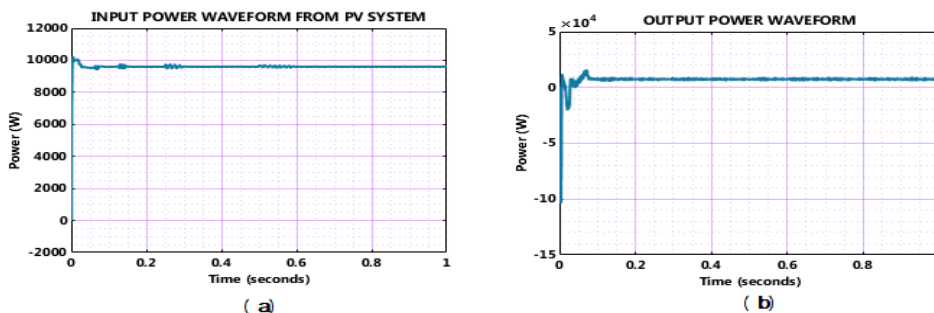

Figure 4.3 Input and output power

Figure 4.3 denotes Input and Output power waveform, where input power rapidly rises to 10000 W and slightly drops down to 9990 W to remain stable, While output power shows light fluctuations in the beginning and further stabilizes after 0.1 seconds respectively.

Research Through Innovation

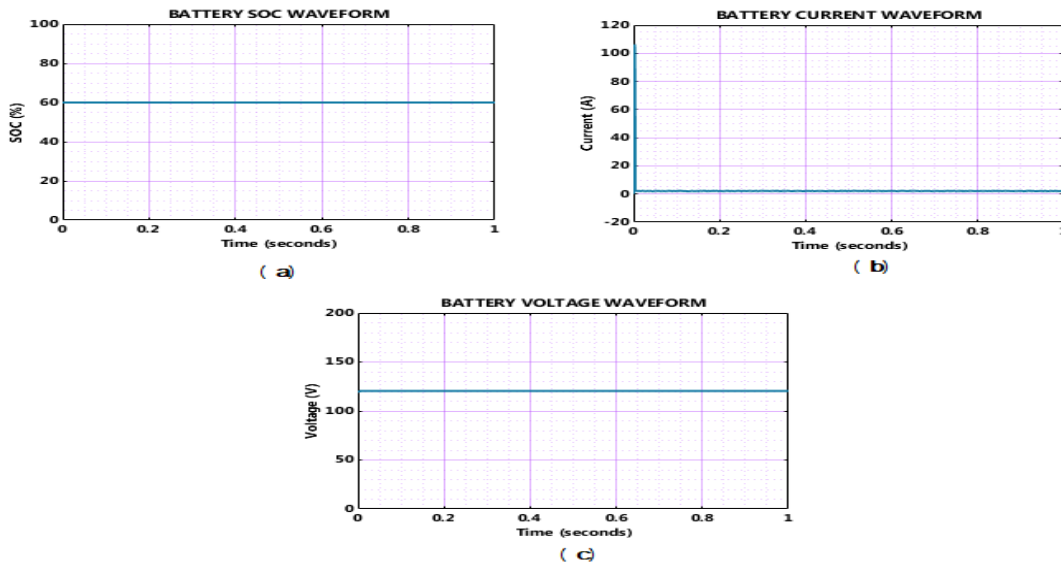

Figure 4.4 Battery SOC, current and voltage

Figure 4.4 refers battery SOC current and voltage waveform, in which battery SOC stays put at 60% through the depicted time seconds. Significantly, both battery voltage and current show a consistent and smooth line, indicating enhanced battery performance. Where battery voltage stays fixed at 125V respectively

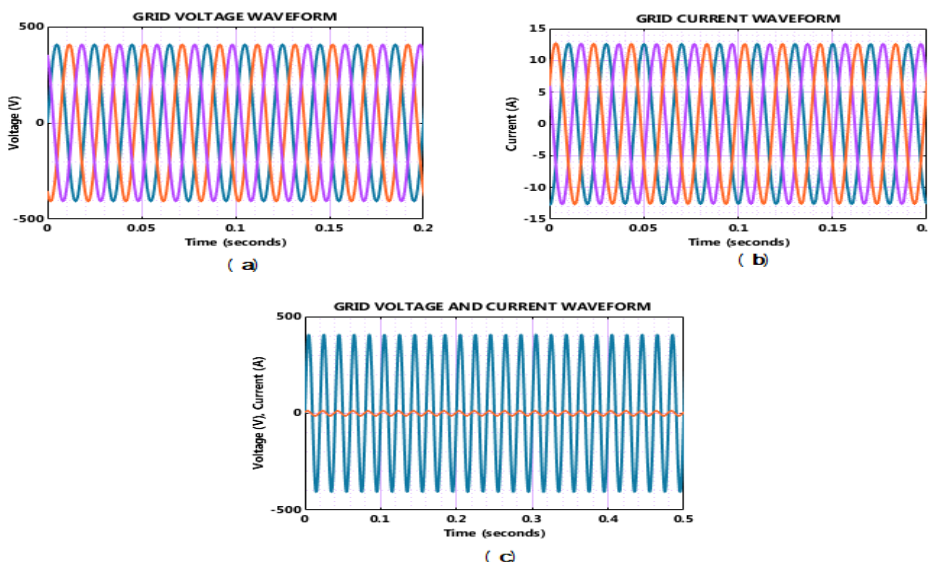

Figure 4.5 Voltage and current waveform for grid

Figure 4.5 showcases grid voltage and current in sinusoidal wave representations, where voltage ranges between ± 400 V and current ranges between ± 12 A respectively. The third graph shows the combination of both grid voltage and current waves, which showcases optimum grid by achieving perfect grid synchronization.

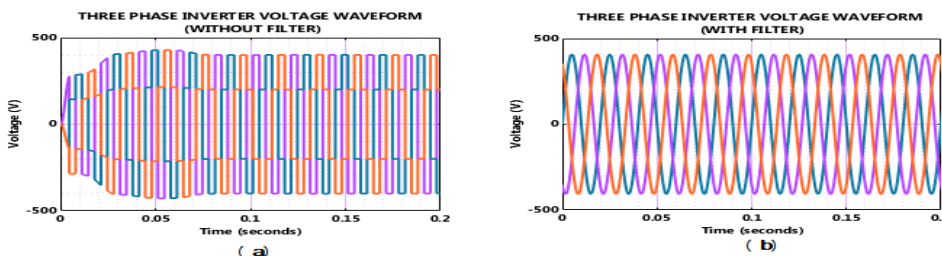

Figure 4.6 Voltage waveform for three phase inverter

Figure 4.6 showcases voltage waveform of for three phase inverter, Figure 4.6(a) depicts the voltage waveform without filter, where voltage shows certain fluctuations with unwanted disturbance. While, Figure 4.6(b) represents the voltage waveform with filter, where voltage shows consistent and stable waves ranging between ± 400 V respectively.

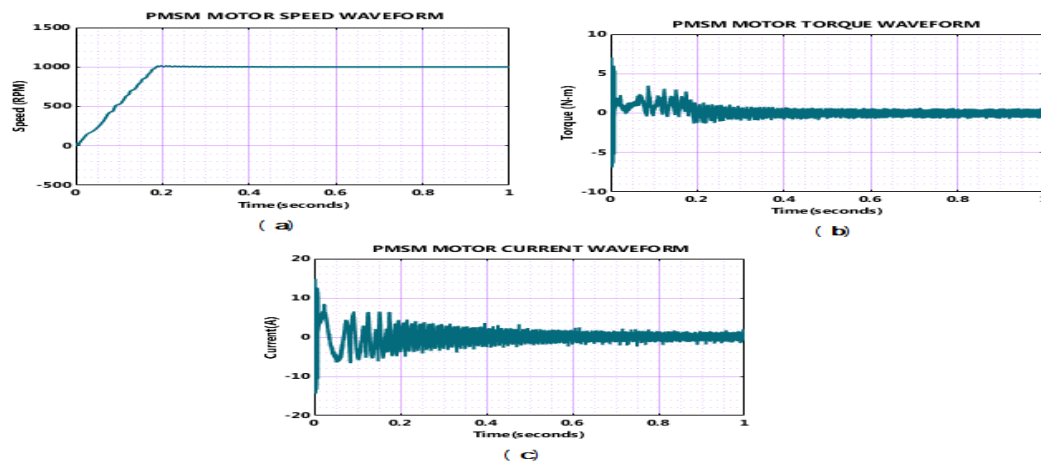

Figure 4.7 PMSM speed, torque and current waveform

Figure 4.7 demonstrates PMSM motor speed, torque and current waveform, in the first graph the PMSM motor speed progressively increases to 1000 RPM at 0.2 seconds, then motor speed is maintained at that speed. From the second graph it is notable that, PMSM torque considerably low at 1 N-m. And third graph showcases that, PMSM motor current initially fluctuates ANF further is maintained at constant respectively.

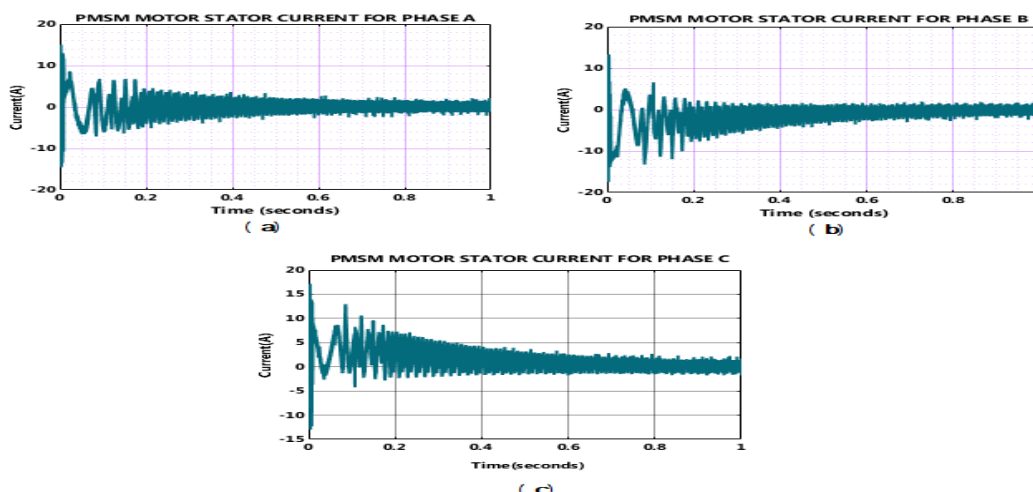

Figure 4.7 PMSM motor stator current

Figure 4.7 represents PMSM motor stator current for three phases namely, (a) Phase A, (b) Phase B and (c) Phase C, where all the three phases shows initial oscillations and further stabilizes. Of the three phases, Phase A and Phase B depicts slightly higher initial oscillation when compared to Phase C, All the three graph depicts the motor's characteristics of increased stability.

V. CONCLUSION

In conclusion, this project presents an efficient control strategy for a renewable energy system that integrates a PV system, a high-gain switched quasi Z-source converter, and a bidirectional DC-DC converter. The system effectively regulates energy flow between the PV source, battery storage, and power loads, with a primary focus on electric vehicle applications powered by a Permanent Magnet Synchronous Motor (PMSM). By employing Pulse Width Modulation (PWM) techniques and an optimized Dolphin POD-based PI controller, the system ensures stable voltage regulation and enhanced performance. The incorporation of both three-phase and single-phase voltage source inverters (VSIs) enables efficient power distribution. Overall, the proposed approach enhances energy utilization, improves response time, and ensures system stability, contributing to sustainable energy solutions. The MATLAB 2021a Simulink implementation validates the system's feasibility and effectiveness, demonstrating its potential for renewable energy integration in electric vehicles.

REFERENCES:

1. H. Lin, M. S. Khan, J. Ahmad, H. -D. Liu and T. -C. Hsiao, "Design and Analysis of Novel High-Gain Boost Converter for Renewable Energy Systems (RES)," in IEEE Access, vol. 12, pp. 24262-24273, 2024.
2. Tian, S. Chen, X. Ding, J. Peng and Z. Kou, "Isolated High Step-Up Soft-Switching Quasi-Z-Source DC-DC Converter," in IEEE Access, vol. 12, pp. 49927-49936, 2024.
3. Naqvi, Syed Shehryar Ali, et al. "Multi-objective optimization of PI controller for BLDC motor speed control and energy saving in Electric Vehicles: A constrained swarm-based approach." Energy Reports 12 (2024): 402-417.
4. K. Selvaraj, G. D. A. Jebaselvi, M. H. Alsharif and M. -K. Kim, "Boundary Value Controlled Gamma Z-Source Inverter for Pump Applications," in IEEE Access, vol. 12, pp. 24396-24411, 2024.
5. Kassem et al., "Enhanced Multiphase Interleaved Boost Converter Interface for Grid-Connected PV Power System," in IEEE Access, vol. 12, pp. 151940-151954, 2024.

6. E. Giglio, R. Novo, G. Mattiazzo and D. Fioriti, "Reserve Provision in the Optimal Planning of Off-Grid Power Systems: Impact of Storage and Renewable Energy," in *IEEE Access*, vol. 11, pp. 100781-100797, 2023.
7. Ahmadifar, M. Ginocchi, M. S. Golla, F. Ponci and A. Monti, "Development of an Energy Management System for a Renewable Energy Community and Performance Analysis via Global Sensitivity Analysis," in *IEEE Access*, vol. 11, pp. 4131-4154, 2023.
8. Samadian, M. G. Marangalu, H. Tarzamni, S. H. Hosseini, M. Sabahi and A. Mehrizi-Sani, "High Step-Up Common Grounded Switched Quasi Z-Source DC–DC Converter Using Coupled Inductor With Small Signal Analysis," in *IEEE Access*, vol. 11, pp. 120516-120529, 2023.
9. M. Ali et al., "An Enhanced P&O MPPT Algorithm With Concise Search Area for Grid-Tied PV Systems," in *IEEE Access*, vol. 11, pp. 79408-79421, 2023.
10. Haque, Md Rezanul, K. M. A. Salam, and Md Abdur Razzak. "A modified PI-controller based high current density DC–DC converter for EV charging applications." *IEEE Access* 11 (2023): 27246-27266.
11. B. K. Santhoshi, K. M. Sundaram, A. Hussain, P. Sanjeevikumar, J. B. Holm-Nielsen, and V. K. Kaliappan, "Deep Learning for Fault Diagnostics in Bearings, Insulators, PV Panels, Power Lines, and Electric Vehicle Applications—The State-of-the-Art Approaches," in *IEEE Access*, vol. 9, pp. 41246-41260, 2021
12. Santhoshi, B.K., Mohanasundaram, K. & Kumar, L.A. ANN-based dynamic control and energy management of inverter and battery in a grid-tied hybrid renewable power system fed through switched Z-source converter. *Electr Eng* 103, 2285–2301 (2021). <https://doi.org/10.1007/s00202-021-01231-7>.
13. Kavya Santhoshi, B.; Mohana Sundaram, K.; Padmanaban, S.; Holm-Nielsen, J.B.; K. K., P. Critical Review of PV Grid-Tied Inverters. *Energies* 2019, 12, 1921. <https://doi.org/10.3390/en12101921>.

