



# Embedded based Speed Monitoring of Induction Motor using Android Application

Shiba Ahmad

Department of Electrical Engineering,  
SSTP, Nagpur (India).

**Abstract**— This paper presents works on GSM based speed monitoring of Induction motor in real time implementation. In this works its belongs to live industrial proto type project has to support or help to industrial persons in their works. The speed of Induction motor monitoring by an embedded system where microcontroller works as a receiver. Its receives output from proximity sensor connected in front of Induction motor and display results on scrolling LED by RS 232 serial communication connector then using Global system mobile (GSM) communication modem its transmitted output on mobile. For embedded system ATMEGA 162V used. Here one important parameter are performs to found similar output simultaneously display on smart mobile phone by using Android application.

As the now a day industries growth huge amount and they are used AC motor, Induction motor they has been used some new technique for their proposal and enhance their performance. This paper works help to monitoring speed of motor.

*Index term; GSM, LED, Induction motor & ATmega162V.*

## I. INTRODUCTION

The “Epsilon Cables Pvt. Ltd.,” most prominent supplier of cable in vidarbha region of Maharashtra. It was established in 1998 by group of engineering and industry professionals with the objective of meeting growing demands of specialized products that are cost-effective. The company has diversified into a series of such product over the year. Development of lift cables, heat resistant cables for boiler application, data cables for long distance application composite cables for multiple application and some more products have been the outcome of such efforts. The company faces some production problems, the labours are do not work properly and also not complete their task on the time. They manually decrease the speed of induction motor and slowly collect the manufactured cable. Therefore company get less production and hence facing the problems. The paper shows the works for the proposed system to monitoring the speed of induction motor.

For the improvement of quality product many industrial application requires adjustable speed and constant speed. Due to rapid advance in automation and process control the field of adjustable speed drives continuously. In recent technology, various alternate techniques are available for the selection of speed of drive system. Up to the 1980 the dc motor was the choice for variable speed drive

application. Induction motors are using any application such as Industrial drives control, automotive control, etc. The project has been designed to develop a speed control system for DC motor in all the four-quadrant. Using four-quadrant chopper it is possible to demonstrate forward, instant forward brake, reverse, instant reverse brake control of a DC motor using triac based microcontroller through remotely operated commands to it by touch screen based user friendly GUI on any smart phone with Android applications.

The speed of the AC motor is measured using wireless measurement technique. Speed monitoring is done through proximity sensor. The proximity sensor which works on +5V is connected in front of the motor. The output of proximity sensor is given to the microcontroller. This project works on +5V power supply that consists of a step down transformer, bridge rectifier, IC regulator 7805, electrolytic capacitor for filtration. The output of power supply section is applied to the microcontroller, proximity sensor and GSM. Microcontroller used in our project is ATMEGA 162 V. The reason for using this microcontroller is because we need to connect GSM modem and LED scrolling display using serial communication. So, in total two serial ports will be required and ATMEGA 162 V has two serial ports namely; RX0 and TX0, RX1 and TX1. When the proximity sensor detects the speed of the motor then this speed value is given to the microcontroller. The microcontroller then using serial communication forwards the speed value to the LED scrolling display and simultaneously the same speed value is forwarded to the GSM modem. Once GSM receives the speed value, it then transmits the speed to the android app using GPRS. Hence, any one in a remote distance can also monitor the speed on his/her android app. Thus, we can monitor the speed on the LED scrolling display as well as on the android application.

## II. RELATED WORK

P.E. Elavenil, Dr. R. Kalaivani in their work “speed monitoring and protection of motor using zigbee Communication”, have been presented monitoring the speed, torque and protection of three phase induction motor from overload by implementing ZigBee based wireless sensor network. The design of the system maintains security, provides high reliability and are susceptible to

many types of faults. The system has transmitter and receiver section which are controlled by microcontroller. The communication between those sections are made by ZigBee transmitter and receiver section. The parameters such as voltage, current, speed and torque of induction motor were monitored. The monitored values are displayed in PC and as SMS in mobile through GSM technology. If overload condition occurs, relay driver circuit will open and makes the motor to turn OFF. Thus input values are maintained within the limit and speed of the motor will be in a controlled manner.

P. Sakthivel and J. Sarathi, in their work “Embedded based speed and torque monitoring in induction motors using GSM control,” have presented the work on monitoring the speed and torque in induction motors in real time by employing ZigBee based wireless sensor network. A noninvasive method was used to acquire electrical signals and the speed and the torque were estimated. Embedded system has been employed to control the speed of the motor and these values are transmitted to a monitoring unit through ZigBee based wireless sensor network. The real time monitoring of various motors can be done at the base unit.

Abhishek Gupta, Siddharth Khinchi, Sidharth Jindal, Tejpal Singh and Sneha Sharma in their work “Induction Motor speed control using Android Application,” have presented their work in which they have been able to control the speed of the induction motor using the android phone. Android mobile act as a transmitter and the received by Bluetooth receiver interfaced to AVR microcontroller of 8051 family.

Arun Nadh and Lakshmi Praba N in their work, “Automatic speed and torque monitoring in induction motors using ZigBee and SMS” have presented a system which aims at monitoring the speed and torque in induction motors. Using an embedded system the electrical signals were obtained in a non-invasive method and the data was processed to estimate the speed and the .The values calculated by the embedded system are transmitted to a monitoring unit through a ZigBee based wireless sensor network. Local processing capability is essential for this type of application.

Prof.A.P.Paranjape, D.B.Palamkar “A Review of Parameter Monitoring &Controlling System for Three Phase Induction Motor Using PLC & SCADA” presented Now a days industries have gradually shifted from conventional relay logic control to intelligent programmable logic control. Three phase induction motors are mostly used AC motors in industry for various operations. Here the review of monitoring and control system for the induction motor based on programmable logic controller (PLC) & SCADA is described. Also the implementation of a hardware and software for speed control, direction control, parameter monitoring on SCADA screen and protection is provided. Variable Frequency Drives (VFD) can also be used to control the motor rotation direction and rotation speed of the three phase induction motor. All the required control and motor performance monitoring parameter data will be taken to a personal computer by SCADA Software Wonderware InTouch via PLC for further analysis.

Pankaj Verma and J.S Bhatia, “Design and Development of GPS-GSM Based Tracking System with Google Map Based Monitoring”, have presented the monitoring unit consists of a GSM mobile and a Web Application. The GSM mobile will acquire the position of the vehicle (longitude and

longitude) and then by typing those co-ordinates in web application owner of vehicle can get the exact location of the vehicle. The web application part is covered later in this paper. In this using 40 pin ATmega16 microcontroller. It has four input–output ports. ATmega16 microcontroller is the heart of the project that is used for interfacing. Two pins are VCC pins and other two pins are at ground. Pin 9 is reset pin. A crystal oscillator of 12 MHz is connected to the microcontroller. RS-232 protocol is used as serial communication between the microcontroller, GPS and GSM modem. A serial driver MAX232, 16 pin IC is used for converting RS-232 voltage levels into TTL voltage levels. There are four electrolytic capacitors which are used with MAX232. A 9V battery is used to power the circuit. A 7805 regulator is used to convert 9V into 5V. The microcontroller and MAX232 are powered by 5V. LED indicates the presence of power supply.

III. SYSTEM ARCHITECTURE

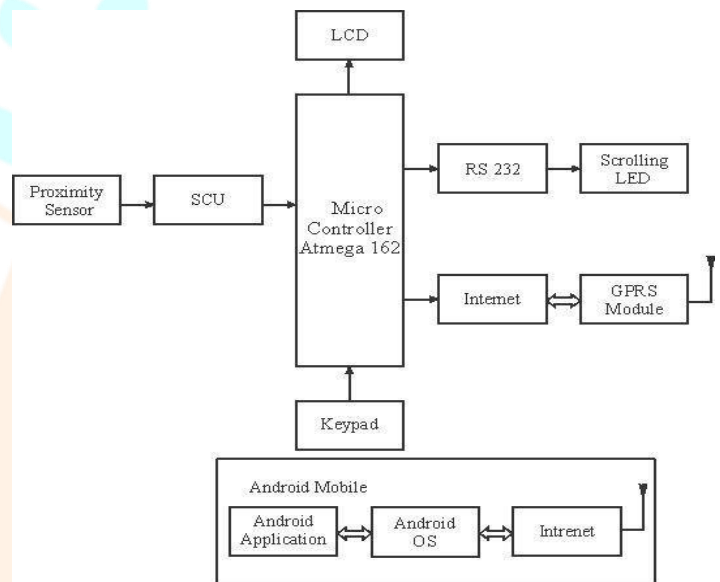

Figure 1 Block diagram

Power Supply

The ac voltage, typically 220V rms, is connected to a transformer, which steps that ac voltage down to the level of the desired dc output. A diode rectifier then provides a full-wave rectified voltage that is initially filtered by a simple capacitor filter to produce a dc voltage. This resulting dc voltage usually has some ripple or ac voltage variation. A regulator circuit removes the ripples and also remains the same dc value even if the input dc voltage varies. This voltage regulation is usually obtained using one of the popular voltage regulator IC units.

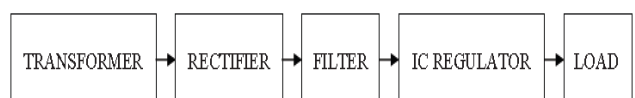

Figure 2 Power Supply

IC voltage regulators

Voltage regulators comprise a class of widely used ICs. Regulator IC units contain the circuitry for reference source, comparator amplifier, control device, and overload protection all in a single IC. IC units provide regulation of

either a fixed positive voltage, a fixed negative voltage, or an adjustably set voltage. A fixed three-terminal voltage regulator has an unregulated dc input voltage, it is applied to one input terminal, a regulated dc output voltage from a third terminal, with the second terminal connected to ground.

**Atmega 162 V**

The ATmega162 is a low-power, high-performance CMOS 8-bit microcontroller with 8K bytes of in-system programmable Flash memory. The device is manufactured using Atmel’s high-density nonvolatile memory technology and is compatible with the industry-standard 80C51 instruction set and pinout. The on-chip Flash allows the program memory to be reprogrammed in-system or by a conventional nonvolatile memory programmer. By combining a versatile 8-bit CPU with in-system programmable Flash on a monolithic chip, the Atmel AT89S52 is a powerful microcontroller which provides a highly-flexible and cost-effective solution to many embedded control applications. The AT89S52 provides the following standard features: 8K bytes of Flash, 256 bytes of RAM, 32 I/O lines, Watchdog timer, two data pointers, three 16-bit timer/counters, a six-vector two-level interrupt architecture, a full duplex serial port, on-chip oscillator, and clock circuitry. In addition, the AT89S52 is designed with static logic for operation down to zero frequency and supports two software selectable power saving modes. The Idle Mode stops the CPU while allowing the RAM, timer/counters, serial port, and interrupt system to continue functioning. The Power-down mode saves the RAM contents but freezes the oscillator, disabling all other chip functions until the next interrupt or hardware reset.

**LCD**

LCD (Liquid Crystal Display) screen is an electronic display module and find a wide range of applications. A 16x2 LCD display is very basic module and is very commonly used in various devices and circuits. These modules are preferred over seven\_segments and other multi segment LEDs. The reasons being: LCDs are economical; easily programmable; have no limitation of displaying special & even custom characters (unlike in seven segments), animations and so on.

**GSM**

A GSM modem is a specialized type of modem which accepts a SIM card, and operates over a subscription to a mobile operator, just like a mobile phone. From the mobile operator perspective, a GSM modem looks just like a mobile phone. A GSM modem exposes an interface that allows applications such as Now SMS to send and receive messages over the modem interface. The mobile operator charges for this message sending and receiving as if it was performed directly on a mobile phone. To perform these tasks, a GSM modem must support an “extended AT command set” for sending/receiving SMS messages, as defined in the ETSI GSM 07.05 and 3GPP TS 27.005 specifications. GSM modems can be a quick and efficient way to get started with SMS, because a special subscription to an SMS service provider is not required. In most parts of the world, GSM modems are a cost effective solution for receiving SMS messages, because the sender is paying for the message delivery.

**MAX 232 and RS232**

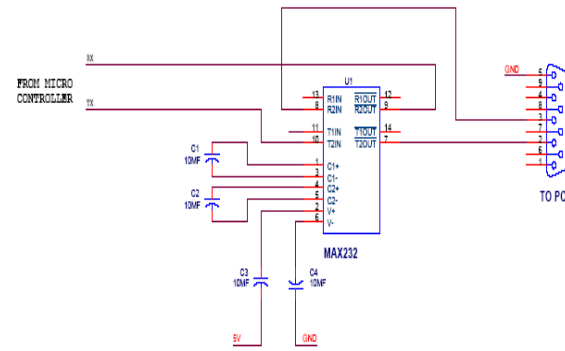

Figure 3 MAX 232 Circuit

In telecommunications, **RS-232** is a standard for serial binary data interconnection between a *DTE* (Data terminal equipment) and a *DCE* (Data Circuit-terminating Equipment). It is commonly used in computer serial ports.

**LED SCROLLING DISPLAY**

A light-emitting diode (LED) is a two-lead semiconductor light source that resembles a basic pin-junction diode, except that an LED also emits light. An LED is often small in area (less than 1 mm<sup>2</sup> ) and integrated optical components may be used to shape its radiation pattern. Infrared LEDs are still frequently used as transmitting elements in remote-control circuits, such as those in remote controls for a wide variety of consumer electronics. The first visible-light LEDs were also of low intensity, and limited to red. Modern LEDs are available across the visible, ultraviolet, and infrared wavelengths, with very high brightness. Early LEDs were often used as indicator lamps for electronic devices, replacing small incandescent bulbs. They were soon packaged into numeric readouts in the form of seven-segment displays, and were commonly seen in digital clocks. Recent developments in LEDs permit them to be used in environmental and task lighting. LEDs have many advantages over incandescent light sources including lower energy consumption, longer lifetime, improved physical robustness, smaller size, and faster switching. Main logic of the moving display is the scanning process.

**PROXIMITY SENSOR**

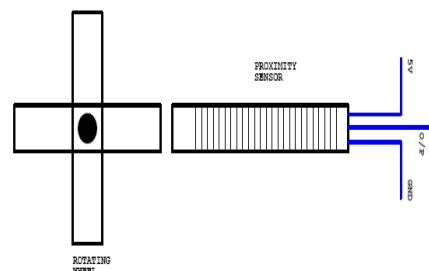

Figure 4 Proximity Sensor

Inductive proximity sensors are widely used in various applications to detect metal devices. Inductive proximity sensors generate an electromagnetic field and

detect the eddy current losses induced when the metal target enters the field. The field is generated by a coil, wrapped round a ferrite core, which is used by a transistorized circuit to produce oscillations. The target, while entering the electromagnetic field produced by the coil, will decrease the oscillations due to eddy currents developed in the target. If the target approaches the sensor within the so-called "sensing range", the oscillations cannot be produced anymore: the detector circuit generates then an output signal controlling a relay or a switch.

#### IV. IMPLEMENTATION DETAILS

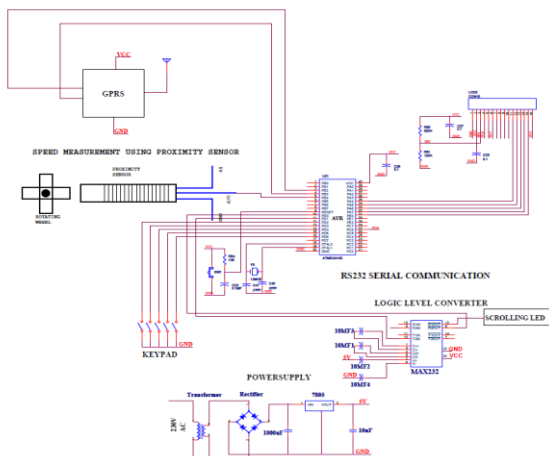

Figure 5 Circuit Diagram of the Hardware implementation



Figure 6 The actual hardware implementation

The speed of the AC motor is measured using wireless measurement technique. Speed monitoring is done through proximity sensor. The proximity sensor which works on +5V is connected in front of the motor. The output of proximity sensor is given to the microcontroller. This project works on +5V power supply that consists of a step down transformer, bridge rectifier, IC regulator 7805, electrolytic capacitor for filtration. The output of power supply section is applied to the microcontroller, proximity sensor and GSM.

Microcontroller used in our project is ATMEGA 162 V. The reason for using this microcontroller is because we need to connect GSM modem and LED scrolling display using serial communication. So, in total two serial ports will be required and ATMEGA 162 V has two serial ports namely; RX0 and TX0, RX1 and TX1.

When the proximity sensor detects the speed of the motor then this speed value is given to the microcontroller. The microcontroller then using serial communication forwards the speed value to the LED scrolling display and simultaneously the same speed value is forwarded to the GSM modem. Once GSM receives the speed value, it then transmits the speed to the android app using GPRS. Hence, any one in a remote distance can also monitor the speed on his/her android app. Thus, we can monitor the speed on the LED scrolling display as well as on the android app.

#### V. RESULTS

1) Result showing on LCD of proposed system:

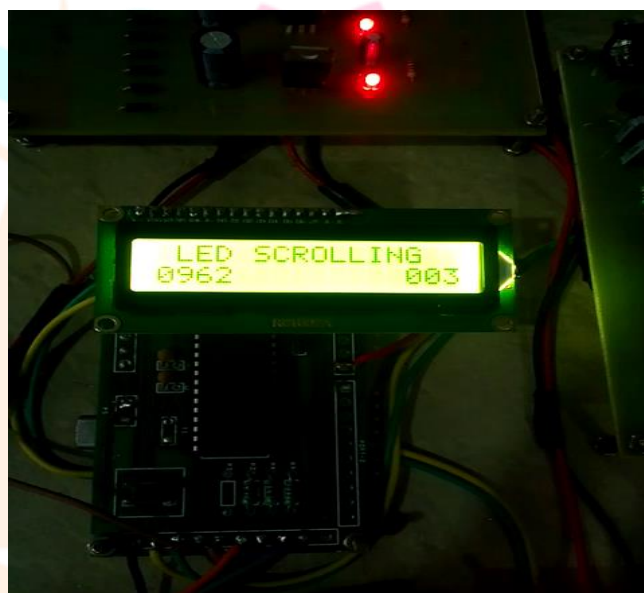

2) Display results on scrolling LED



#### VI. CONCLUSION

We conclude that, the propose system is to be used monitoring speed of induction motor by the using android application. The system has been also the provision to controlling the speed of induction motor and the demand for wireless operating device have been increasing and such devices are preferred over wired devices. Integrating features of all the hardware components used have been developed in it. This system has also addressed the applying in different industrial environment also.

## REFERENCES

- [1] P. Sakthivel and J. Sarathi, "Embedded based speed and torque monitoring in induction motors using GSM control," ISSN (PRINT) : 2320 – 8945, Volume – 2, 2014.
- [2] Abhishek Gupta, Siddharth Khinchi, Sidharth Jindal, Tejpal Singh and Sneha Sharma, "Induction Motor speed control using Android Application," International Journal of Electrical and Electronics Research, ISSN 2348 – 6988, Vol. 4, Issue 2, April-June 2016.
- [3] Arun Nadh and Lakshmi Praba N, "Automatic speed and torque monitoring in induction motors using ZigBee and SMS," IEEE International Conference on Emerging Trends in Computing, Communication and Nanotechnology (ICECCN) 2013.
- [4] S.Sumeetha and D.Sharmila, "Embedded based Remote Control Application using Mobile Phone in Irrigation," International Journal of Power Control Signal and Computation (IJPCSC) ISSN: 0976-268X Vol3. No1. Jan-Mar 2012.
- [5] "Thyristor controlled power for induction motor (ISSN 2319-9725)" from international journal of innovative research & studies by Devendra kumar Shukla & Sudhanshu Tripathi.
- [6] "Speed control of single phase induction motor using AC chopper by asymmetrical PWM method" from IJAREEIE by R. Suneeth and P. Usha.
- [7] "Speed control of induction motor using TRIAC" by Prachi M. Palpankar, Sanraj Harle, Tushar Karade, Suraj Lekurwale.
- [8]. "Speed control of single phase AC induction motor using microcontroller" from IJERA by Chaitanya N. Jibhakate, Asst. Prof. Vijaya Huchhe.
- [9]. "Development of single phase induction motor adjustable speed control using M68HC11E-9 microcontroller" from journal of applied sciences by Senan M. Bashi, I. Aris and S. H. Harmad.
- [10] "Speed control and Monitoring of AC motor by wireless communication using DTMF decoder technique" form international journal of engineering and science by Asst. Prof. Burali Y. N and Patil R. T.
- [11] P.E. Elavenil, Dr. R. Kalaivani in their work "speed monitoring and protection of motor using zigbee Communication", International Journal of Advanced Research in Electrical, Electronics and Instrumentation Engineering issn (print) : 2320 – 3765 vol. 6, issue 2, february 2017

