



PREDICTIVE CONTROL OF PMSG BASED PHOTOVOLTAIC AND WIND HYBRID POWER SYSTEM

BODDU MOUNIKA¹, V. SURYA PRAKASH², D. MAHESH KUMAR³

¹ M.Tech Scholar Dept. of Electrical & Electronics Engineering, PVKKIT, Anantapur.

² Assistant Professor Dept. of Electrical & Electronics Engineering, PVKKIT, Anantapur.

³ Associate Professor Dept. of Electrical & Electronics Engineering, PVKKIT, Anantapur.

ABSTRACT

With the harmful effects of fossil fuel combustion on the environment, in addition to limited stock of fossil fuel, has forced many countries to inquire into and change to eco-friendly alternatives that are renewable to sustain the increasing energy demand. Though there is prospect of power generation from renewable energy sources such as wind, solar, geo-thermal, biomass, etc, solar and wind power generation are two of the most promising renewable power generation technologies.

In general, solar and wind powers are complementary in nature. Therefore, the hybrid photo-voltaic and wind energy system has higher dependability to give steady power and deliver power to the load mutually or independently. In solar photo-voltaic system, MPPT technique is applied to maximize power output. In wind energy conversion system, PMSG (PERMANENT MAGNET SYNCHRONOUS GENERATOR) is driven by wind turbine with zero pitch angle.

In this paper, the architecture with modelling and simulation of hybrid solar photo-voltaic and wind energy sources has been provided. The simulation of solar photovoltaic and PMSG based wind hybrid system has been carried out with MATLAB/SIMULINK and simulation results are provided.

INTRODUCTION:

The increasing consumption of fossil fuels and the associated environmental concerns have directed global attention toward renewable energy sources. Utilizing a combination of two or more renewable energy sources proves to be more cost-effective, efficient, and reliable compared to single-source systems. Carefully selecting appropriate renewable energy sources can significantly reduce dependence on fossil fuels, thereby enhancing the sustainability of power generation.

Due to the growing challenges associated with industrial fuels such as oil and gas, the development and adoption of renewable energy sources are steadily progressing. This growing importance of renewable energy stems from several factors, including their abundant availability, eco-friendly nature, and recyclability. Various renewable energy sources such as solar, wind, hydro, and tidal power exist, among which solar and wind energy are the fastest-growing. These energy sources facilitate power generation through photovoltaic (PV) cells and wind turbines without emitting harmful pollutants.

With the rapid increase in electricity demand, existing base load power plants are struggling to meet supply requirements. Renewable energy sources can help bridge the gap between demand and supply, especially during peak load periods. Moreover, small-scale standalone power generation systems utilizing renewable sources are particularly useful in remote areas where conventional power infrastructure is impractical.

A standalone wind/PV hybrid generation system provides an efficient solution for distributed power generation in isolated regions without access to utility grids. The pollution-free nature of such systems makes them even more appealing. A practical approach to self-sufficient power generation in remote areas involves integrating wind turbines with a PV system to create a standalone hybrid setup. Modern wind turbine systems typically employ various types of AC generators, including Wound-Rotor Induction Generators, Doubly-Fed Induction Generators (DFIG), Squirrel-Cage Rotor Induction Generators, and Synchronous Generators (with external field excitation). However, for this study,

a Permanent Magnet Synchronous Generator (PMSG) wind system is chosen due to its superior efficiency and lower maintenance requirements. PMSG-based systems eliminate the need for a gearbox, reducing nacelle weight and overall costs.

In this thesis, a wind-PV hybrid power generation system is analyzed and simulated. Hybrid systems offer greater reliability compared to standalone power generation, as they ensure continuous electricity supply even if one of the sources is temporarily unavailable. A block diagram of the complete hybrid system is presented below.

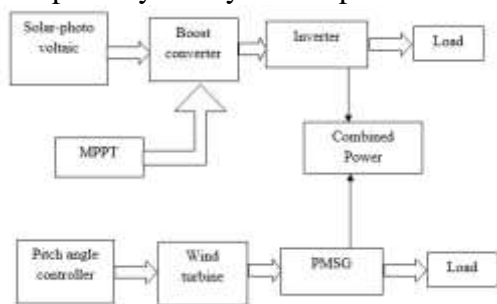

Fig 1. Block diagram of hybrid system

Advantages of Hybrid Systems

- A major benefit of hybrid systems is their ability to provide power to remote, non-electrified regions where grid connectivity is unavailable.
- Combining solar and wind power enhances system reliability, ensuring a continuous power supply.
- When solar energy is unavailable, wind energy is often sufficient to generate electricity.
- Wind speeds tend to be lower in summer when solar energy is at its peak, and stronger in winter when solar energy is less available. This complementary nature enhances the efficiency of hybrid systems.
- Hybrid systems are ideal for applications requiring improved performance and output, as they optimize energy generation by balancing the cyclical nature of solar and wind resources across different times of the day or seasons.

SOLAR POWER SYSTEM

Photovoltaic System

A photovoltaic (PV) system, also known as a solar PV power system, is designed to generate usable electricity from sunlight using photovoltaic technology. It consists of several key components, including PV panels that capture and convert sunlight into electricity, a solar inverter that converts direct current (DC) into alternating current (AC), as well as mounting structures, cabling, and other electrical accessories required

to establish a functional system. Additionally, PV tracking systems are often integrated to improve overall system efficiency.

A solar array refers specifically to the collection of solar panels—the most visible part of a PV system—while the remaining components, often collectively referred to as the Balance of System (BOS), ensure the complete functionality of the setup.

Solar PV systems exhibit distinct and advantageous characteristics in energy conversion. They operate by responding to light and converting a portion of it into electrical energy through a unique process. The key benefits of photovoltaic systems include:

- No moving parts, reducing mechanical wear and tear.
- No requirement for gases or fluids.
- No fuel consumption.
- Immediate response to sunlight, reaching full power output almost instantly.
- Operation under moderate temperature conditions.
- Zero emissions or pollution during electricity generation.
- Minimal maintenance when properly manufactured and installed.
- Composition from silicon, the second most abundant element in the Earth's crust.
- High conversion efficiency, making them one of the most effective methods of converting sunlight into electricity.
- Wide-ranging power capabilities, from microwatts to megawatts.
- Solar energy being an abundant, renewable, clean, and cost-effective resource.

However, photovoltaic energy also has certain limitations:

- Its availability is intermittent, depending on sunlight exposure.
- It can be costly in large-scale applications beyond practicality.

Components of a PV System

A photovoltaic cell converts solar radiation into electrical energy. However, due to its small size, a single solar cell generates only a limited amount of power at fixed voltage and current levels, which may not be suitable for most applications. To make solar electricity usable, multiple solar cells are combined to form a solar panel, also known as a PV module. For large-scale power generation, these panels are further grouped into a solar array. While solar panels are the core component of a PV system, several other essential elements are required to create a fully functional system. These

additional components, known as the Balance of System (BOS), vary depending on whether the system is grid-connected or designed for standalone operation. The most important BOS components include:

- **Mounting Structure:**
Used to secure PV modules and orient them optimally toward the sun for maximum energy absorption.
- **DC-DC Converters:**
These devices regulate the variable voltage output from the solar panels, adjusting it to a fixed voltage suitable for charging batteries or serving as input for an inverter in grid-connected systems.
- **Inverters (DC-AC Converters):**
Inverters convert the DC electricity generated by the PV panels into AC power, making it compatible with the electrical grid and common household appliances.
- **Cables:**
Used to interconnect the various components of the PV system and deliver power to electrical loads. Choosing cables of adequate thickness minimizes resistive losses and ensures efficient energy transfer.

While not technically part of the PV system itself, the electrical loads—such as appliances and devices connected to the system—must be carefully considered during system design. It is also essential to determine whether the connected loads operate on AC or DC power.

SERIES AND PARALLEL COMBINATION OF PV CELLS:

PV Cells in Series:

When two identical cells are connected in series, the short circuit current of the system would remain same but the open circuit voltage would be twice as much as shown in the following figure:

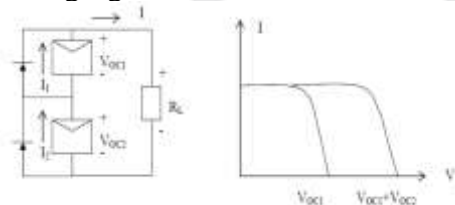

Fig 2. Series connection of PV cells

PV Cells in Parallel:

When two cells are connected in parallel as shown in the following figure, the open circuit voltage of the system would remain same as a open circuit voltage of a single cell, but the short circuit current of the

system would be twice as much as of a single cell.

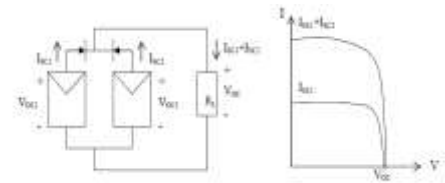

Fig. 3 Parallel connection of PV cells

MAXIMUM POWER POINT TRACKING

Maximum Power Point Trackers (MPPTs) play a crucial role in photovoltaic (PV) systems by enhancing efficiency and optimizing power output. Since PV arrays exhibit a nonlinear voltage-current (V-I) characteristic, there exists a unique point at which power generation is maximized. The power output from a solar panel fluctuates due to varying solar irradiance, temperature, and other environmental factors. To ensure optimal energy extraction, it is essential to operate the photovoltaic (PV) system at its Maximum Power Point (MPP). In this section, the Perturb & Observe (P&O) MPPT algorithm is discussed, which is responsible for controlling the DC-DC boost converter to track and maintain the MPP efficiently [5].

Maximum Power Point Tracking System

The Maximum Power Point Tracking (MPPT) system is an electronic control mechanism designed to extract the highest possible power from a PV system. Unlike mechanical tracking systems that adjust the orientation of solar panels to follow the sun, MPPT systems operate purely electronically. By dynamically adjusting the operating point of the PV modules, MPPT technology ensures that the system delivers the maximum available power. MPPT techniques are essential for maintaining the PV array's operation at its optimal power-generating point.

Necessity of Maximum Power Point Tracking

The Power vs. Voltage (P-V) characteristic of a PV module, as shown in Figure 2.5, reveals the presence of a single peak—the Maximum Power Point—corresponding to a specific voltage and current combination. Given that the overall efficiency of a PV module is relatively low (approximately 12%), it is crucial to operate the system at this peak power point to maximize energy delivery to the load, despite constantly changing environmental conditions.

According to the Maximum Power Transfer Theorem, a circuit achieves maximum power output when the Thevenin's equivalent impedance of the source matches the load impedance. Consequently, tracking the Maximum Power Point

essentially becomes an impedance matching problem.

To achieve this, a DC-DC converter is integrated into the system, positioned between the PV module and the load. This converter maximizes power extraction by adjusting the circuit impedance to match that of the PV module. The process of impedance matching is carried out by varying the duty cycle of the converter's switching elements, which is determined through Maximum Power Point Tracking techniques.

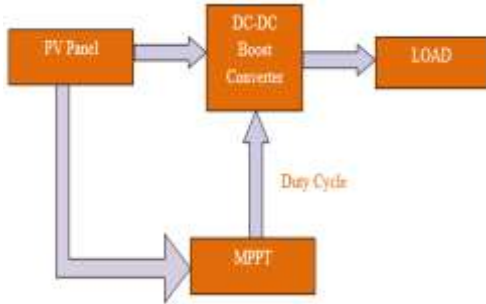

Fig. 4 Circuit arrangement of MPPT

WIND ENERGY CONVERSION SYSTEM

Wind is the movement of air, primarily driven by pressure gradients. On a global scale, one of the key driving forces behind surface winds moving from the poles to the equator is convective circulation. Solar radiation heats the air near the equator, causing it to rise due to its lower density. This rising warm air is replaced at the surface by cooler, denser, high-pressure air flowing in from the poles. Meanwhile, in the upper atmosphere, air moves back toward the poles, completing a large-scale convective cycle. Consequently, the global atmospheric circulation leads to surface winds moving from north to south in the Northern Hemisphere. The Sun's uneven heating of the Earth's surface drives large-scale air movements, which we experience as wind. Wind energy is essentially a secondary effect of solar energy, with about 2% of the solar radiation reaching the Earth being converted into wind energy. Variations in the heating and cooling of the Earth's surface cause atmospheric pressure differences, prompting air to flow from high-pressure to low-pressure regions, thereby shaping wind patterns.

Structure of Wind Energy Conversion System:

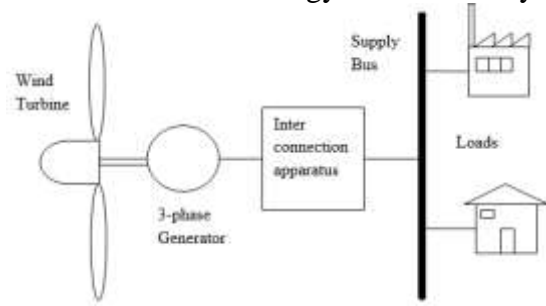

Fig. 5 Structure of a typical wind energy system

The figure above illustrates the structure of a typical Wind Energy Conversion System (WECS). The primary components of a WECS include a wind turbine, generator, interconnection equipment, and control systems.

Wind turbines are generally categorized into two types: horizontal-axis and vertical-axis turbines. Modern wind turbines predominantly utilize a horizontal-axis design, typically incorporating two or three blades, and can function in either upwind or downwind configurations. They can also be designed for fixed-speed or variable-speed operation, with variable-speed turbines capable of generating 8% to 15% more energy than their fixed-speed counterparts. However, they require power electronic converters to ensure a stable frequency and voltage output for their loads.

At present and in the foreseeable future, wind turbine generators primarily consist of synchronous generators, permanent magnet synchronous generators (PMSGs), and induction generators such as squirrel cage induction generators (SQIGs) and wound rotor induction generators. For small to medium-sized wind turbines, SQIGs and PMSGs are preferred due to their affordability and reliability. In contrast, high-power wind turbines commonly utilize PMSGs, induction generators, and wound-field synchronous generators.

Interconnection equipment is essential for power regulation, soft start mechanisms, and seamless grid integration. Power electronic converters play a key role in these processes, with most modern wind turbine inverters utilizing forced-commutated Pulse Width Modulation (PWM) technology to ensure high-quality power output with stable voltage and frequency.

SIMULATION MODELS AND RESULTS

The hybrid system with solar photo-voltaic and wind energy power systems proposed in this thesis was analysed with MATLAB/SIMULINK. Simulation models of MPPT based solar PV system; wind energy conversion system and hybrid system were developed. Simulation results of voltage, current and power were analysed. MATLAB MODELS AND SIMULATION RESULTS:

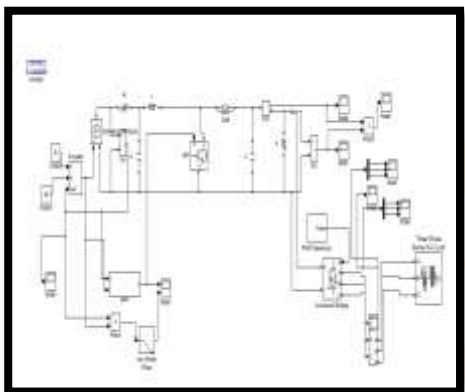

Fig. 6 Simulink block of MPPT based solar PV system

The simulink block of Solar PV system with boost converter, three phase inverter and Maximum Power Point Tracking system and load is shown in above Fig 6

Here, in the above simulation block, 3-arm 6-pulse bridge type inverter has been utilized. The carrier frequency of Pulse Width Modulation signal generator is 4000Hz and sampling time is $5e^{-6}$. Here IGBT based boost converter is used.

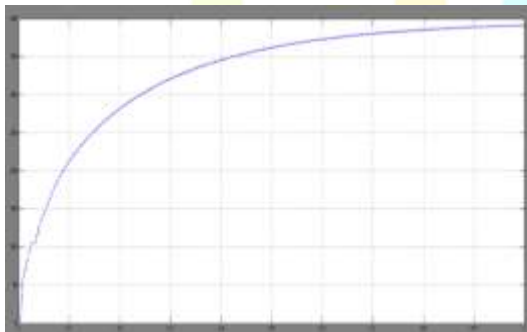

Fig 7 Output voltage after boosting

The output voltage after boost converter has been shown is the above Fig:7. Here, the generated voltage of photo-voltaic system was very low. Since, low voltage is not sufficient, a boost converter is used to boost the voltage. The output voltage is 380V after boosting.

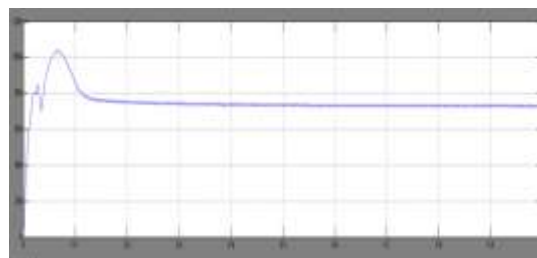

Fig. 8 Maximum power of solar PV system

Here, the maximum power of solar system is shown in the Fig: 8. The maximum power point tracking system has been applied to photovoltaic system. Here, perturb and observe MPPT technique is applied and 720W power has been tracked using this system.

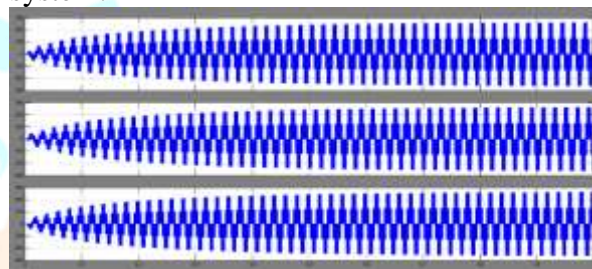

Fig. 9 Three phase inverter voltage (per phase)

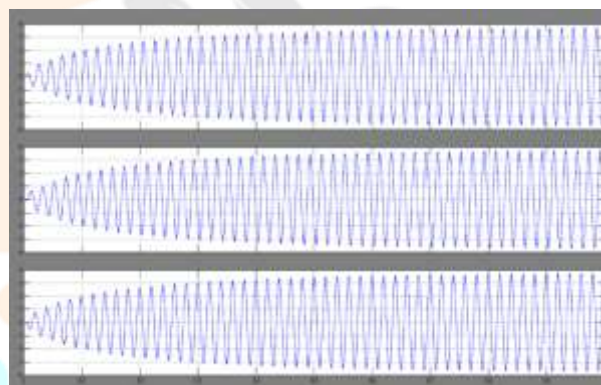

Fig. 10 Three phase inverter current (per phase)

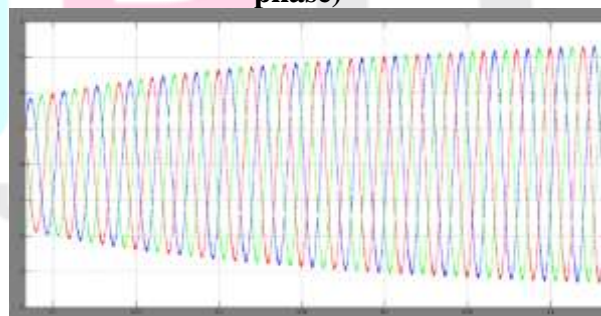

Fig. 11 Current of inverter of solar PV system

The RLC load of 1KW, 500 Q_L is employed to solar system. A Pulse Width Modulation three phase inverter has been utilized for the conversion of boosted voltage from DC-AC. 220V AC voltage per phase has been obtained with 3.5 Amp current.

The above section represents the simulink model of MPPT based solar PV system, their respective waveforms of voltage, current and power respectively. Generated voltage of solar PV system was very low. Since low voltage is not sufficient, a boost converter is used to raise the voltage. The efficiency of the output voltage after boosting is high. Here, in the solar PV, P&O MPPT technique is applied to get maximum power.



Fig. 14 Voltage, current and power of PMSG

Here, the speed, torque, pitch angle of the wind turbine, voltage, current and power of permanent magnet synchronous generator has been shown in the above Fig: 13 and Fig: 14. The total number of poles used here are 10, rated speed is 153 rad/sec, armature resistance is 0.425 Ω, magnetic flux linkage is 0.433 Wb, rated torque is 40 Nm. Here, per phase voltage of permanent magnet synchronous generator is 400V.

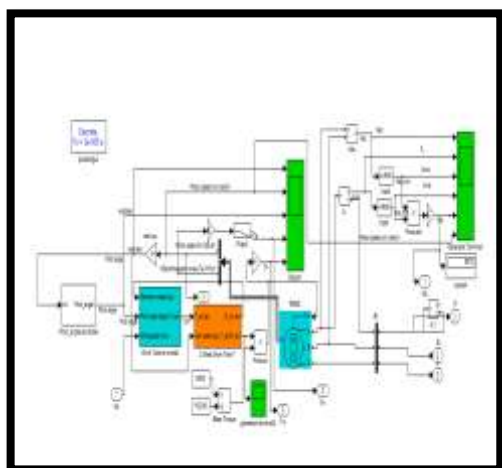

Fig. 12 Simulink block of wind energy conversion system

The simulink block of WECS is shown in the Fig: 12. here, the wind turbine have nominal mechanical output power (W) of 8500, maximum power at base wind speed is 0.8pu, base power of electrical generator (VA) is 8500/0.9, the base wind speed is 12 m/s, selection of parameters of Permanent Magnet Synchronous Generator is done according to power requirement.

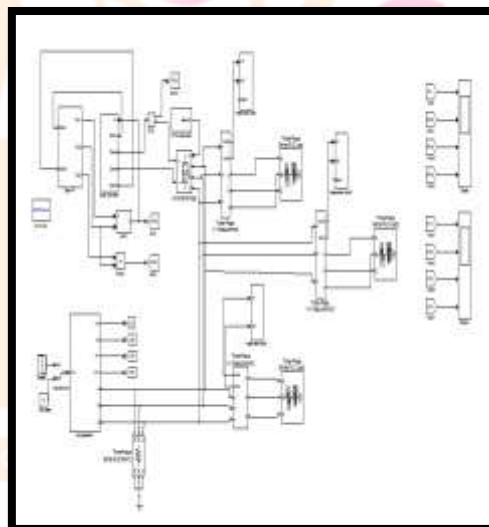

Fig. 15 Simulink block of hybrid system

The simulink block of the solar photovoltaic and permanent magnet synchronous generator based wind hybrid system has been shown in Fig: 5.10. Here, the solar energy and wind energy are combined together to form hybrid power system. In this hybrid system, the number of electrical power storage components and the electrical power generators are merged together to meet the electrical power demand of isolated areas as well as rural areas.

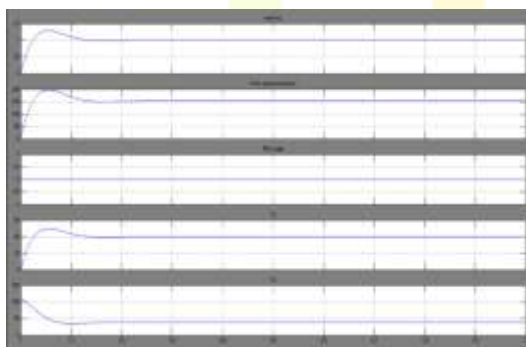

Fig 13 Speed, torque and pitch angle of wind turbine

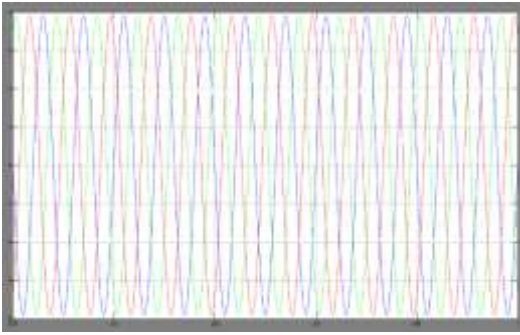

Fig. 16 Current of hybrid system

The load employed here is 1KW, 500 QL. This load is connected to the hybrid system. The current waveform of 7.7 Amp of hybrid system has been shown in the Fig: 5.11.

The final results of voltage, current and power of the solar PV system after boost converter showed a good performance with increase in efficiency. The hybrid system implementation increased the performance of the system when compared to individual systems. The hybrid system obtained the higher efficiency when compared to the individual systems. The simulink models are simulated and the respective results are obtained using MATLAB/SIMULINK model.

CONCLUSION:

This thesis presents a hybrid energy system integrating solar photovoltaic (PV) and wind energy. It provides a structured architecture along with a simulation-based analysis of the hybrid energy sources. The system utilizes solar PV and wind power as primary energy sources.

In the solar PV system, the Perturb & Observe (P&O) MPPT technique is implemented to enhance output voltage, thereby improving the system's overall efficiency.

In the wind energy conversion system, efficiency is optimized using pitch angle control. The pitch angle controller is initially set to zero but can be adjusted as needed.

The hybrid PV-wind energy system offers greater reliability and stable power output compared to standalone systems. The MPPT-based solar PV Vol. 2, Issue 12, Dec. 2012, pp. 12-20

system, wind energy conversion system, and hybrid system were designed and analyzed using MATLAB/SIMULINK. In conclusion, the primary objective of implementing a hybrid system has been successfully achieved.

REFERENCES

- [1] Arjav Harjai, Abhishek Bhardwaj, Mrutyunjaya Sandhibigraha, "Study Of Maximum Power Point Tracking (MPPT) Techniques In A Solar Photovoltaic Array", 2010.
- [2] K.V. Induji, Mr. Vinamzi Paul Samuel, "Simulation of Standalone PV/Wind Hybrid System", International Journal of Engineering Research & Technology (IJERT), Vol. 3 Issue 1, January - 2014, pp. 2374– 2379.
- [3] Arpan Dwivedi, "Benefits of Standalone Power Supply System" International Journal Of Engineering Sciences & Management, Vol. 2, Issue 1, Jan-Mar: 2012, pp. 62-65.
- [4] S. Gomathy, S. Saravanan, Dr. S. Thangavel, "Design and Implementation of Maximum Power Point Tracking (MPPT) Algorithm for a Standalone PV System" International Journal of Scientific & Engineering Research Volume 3, Issue 3, March -2012, pp.1-7.
- [5] Hairul Nissah Zainudin, Saad Mekhilef, "Comparison Study of Maximum Power Point Tracker Techniques for PV Systems", Proceedings of the 14th International Middle East Power Systems Conference (MEPCON'10), December 19-21, 2010 pp.750-755.
- [6] V.C. Kotak, Preti Tyagi, "DC To DC Converter in Maximum Power Point Tracker", International Journal of Advanced Research in Electrical, Electronics and Instrumentation Engineering Vol. 2, Issue 12, December 2013, pp. 6115-6125.
- [7] Moshiur Rahman Sourov, Ummee Tania Ahmed, Mirza Golam Rabbani, "A High Performance Maximum Power Point Tracker for Photovoltaic Power System Using DC-DC Boost Converter", IOSR Journal of Engineering,