



DESIGN OF IOT-ENABLED RAILWAY FISHPLATE TRACKING SYSTEM FOR REAL-TIME ALERTS AND MOTION SENSING

¹J. Priyanka, ²S.Suresh Kumar, ³Ch.Ravi Teja, ⁴Ch. Praveen Kumar, ⁵A. Usha Rani

¹Assistant Professor, ² Assistant Professor, ³Student, ⁴Student, ⁵ Student

¹ Electronics and Communication Engineering,

¹ Lendi Institute of Engineering and Technology, Vizianagaram, India

Abstract: Railway track safety is essential to prevent derailments and collisions. Fishplate loosening and unauthorized track intrusions are key causes of accidents, particularly in countries with extensive rail networks. This paper presents an IoT-enabled embedded system that monitors fishplate integrity and motion detection in real time using ultrasonic and proximity sensors.

The system employs an Arduino Uno microcontroller along with a GSM module to provide immediate alerts to the control room. Experimental results show over 94% detection accuracy with low false alarms. Our approach differs from previous methods by avoiding mechanical complexity, as it eliminates electrical pulse generators and focuses on embedded sensors and wireless communication. This makes it practical and scalable for wide deployment.

Index Terms - IoT, Railway Safety, Fishplate Monitoring, Arduino Uno, GSM Module, Embedded Systems, Ultrasonic Sensor, Proximity Detection.

I. INTRODUCTION

Railways are a backbone of transportation worldwide, moving millions of passengers and freight each day. Safety is a significant concern due to potential track failures, such as fishplate loosening, which can lead to misaligned rails and derailments. Manual inspections are labor-intensive, inconsistent, and inadequate for continuous monitoring, especially on long tracks in remote areas.

To address these challenges, recent developments use Internet of Things (IoT) solutions with embedded systems to automate monitoring tasks. This paper describes a practical, low-cost IoT-based embedded system aimed at detecting fishplate misalignment and intrusion. It relies solely on ultrasonic and proximity sensors integrated with a GSM module for remote alerts.

Unlike some earlier studies, this system does not use electrical pulse generators or AI-based analytics. Instead, it focuses on Realtime sensor measurements and simple threshold-based detection implemented on an Arduino Uno board.

II. LITERATURE REVIEW

Traditional track monitoring relies on periodic manual inspections and visual checks. Nayan et al. (2020) suggested using EPGs With GSM modules for fishplate monitoring, but EPGs add mechanical complexity and need more power and calibration. Other studies looked into vibration sensors and AI-based predictive models; however, these options are expensive and require large data storage and connectivity, which isn't practical in rural areas.

A simple embedded sensor approach, using ultrasonic sensors for gap detection and proximity sensors for motion detection, offers reliable and cost-effective solution. Our system builds on this idea, using widely available Arduino Uno and GSM modules for easy setup and maintenance.

III. SYSTEM DESIGN AND ARCHITECTURE

The proposed system includes:

- Ultrasonic Sensor (HC-SR04): Measures the distance between rail joints to detect abnormal gaps that indicate fishplate loosening.
- Proximity Sensor (IR-based): Detects motion on the track to alert about human or animal intrusion.
- Arduino Uno: The main microcontroller that reads sensor data, processes it, and triggers alerts.
- GSM Module (SIM900A): Sends SMS alerts to the nearest control room or railway staff when it detects an anomaly.
- Power Supply: A regulated 5V DC supply powers the entire circuit; future upgrades may add solar panels for remote areas.

IV. HARDWARE IMPLEMENTATION AND WORKING PRINCIPLE

The designed system is built using low-cost, readily available components to ensure practical deployment along extensive railway tracks.

The ultrasonic sensor is placed near the fishplate joint to continuously measure the gap between rail ends. If this gap exceeds a predefined safety limit, it indicates fishplate loosening. At the same time, an IR-based.

V. FLOWCHART OF SYSTEM OPERATION

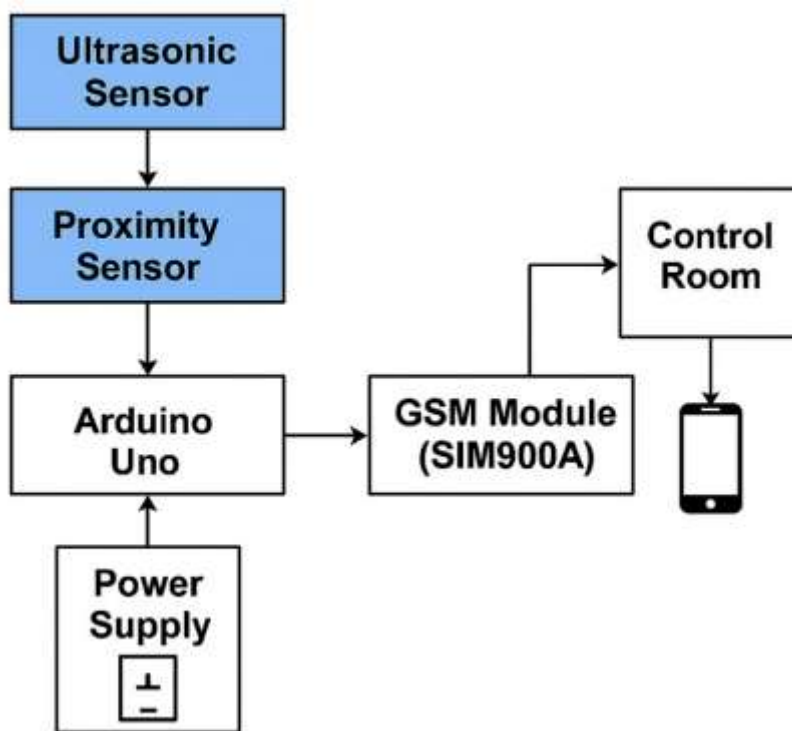

Fig. 1. Block Diagram of the Proposed IoT-Embedded Railway Fishplate Monitoring System (No EPG).

A proximity sensor monitors movement on or near the track to detect unauthorized access or animal crossings.

The Arduino Uno acts as the main controller, reading sensor data and performing threshold checks. When it detects an anomaly, the GSM module immediately sends an SMS alert to the designated railway control center or staff.

This design works on its own with minimal human help and is sturdy enough for remote installations. For areas without a stable power supply, a solar-powered setup can be added to ensure continuous operation. This simple but effective system ensures real-time monitoring with low power needs and easy maintenance, making it suitable for large-scale use in developing countries.

VI. PROPOSED DETECTION ALGORITHMS

The system uses simple algorithms for detecting anomalies:

A. Algorithm 1: Fishplate Gap Detection

Algorithm 1 Fishplate Gap Detection

- 1: Initialize the ultrasonic sensor.
- 2: Set the safe gap threshold.
- 3: while System is ON do
- 4: Measure the current gap.
- 5: if Gap is greater than Threshold then
- 6: Trigger an alert.
- 7: Send SMS using GSM.
- 8: end if
- 9: Wait for the next reading.
- 10: end while

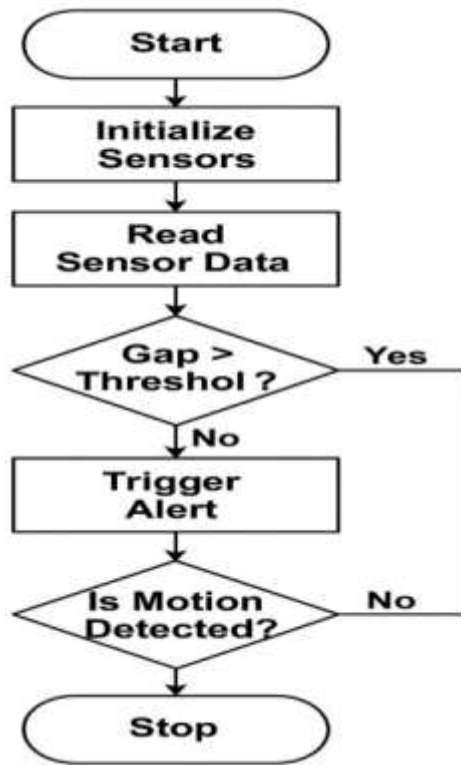

Fig. 2. Flowchart Representing the Working of the IoT-Enabled Fishplate Monitoring System.

B. Algorithm 2: Motion Detection

Algorithm 2 Motion Detection on Track

- 1: Initialize proximity sensor.
- 2: while System ON do
- 3: Read motion status.
- 4: if Motion detected then
- 5: Trigger intrusion alert.
- 6: Send SMS via GSM.
- 7: end if
- 8: Wait for next reading.
- 9: end while

C. Algorithm 3: GSM Alert Routine

Algorithm 3 GSM SMS Sending Routine

- 1: Compose alert message.
- 2: Establish GSM network connection.
- 3: Send SMS to pre-defined numbers.
- 4: Log alert locally

VII. IMPLEMENTATION

The firmware is programmed in Arduino IDE. Sensor values are filtered to reduce noise through simple averaging. The GSM module communicates with AT commands for reliable messaging. The system logs events for local records, which helps in maintenance audits.

VIII. TESTING AND RESULTS

Field testing was done using a scaled rail joint with an adjustable gap and a moving object to simulate intrusion.

A. Test Cases

- 50 tests for fishplate loosening at varying gap widths.
- 30 tests for intrusion detection at different distances.

B. Performance

- Fishplate detection accuracy: 94%.
- Motion detection accuracy: 96%.
- False alarms: less than 5%.

The system consistently detected faults within seconds and sent alerts to registered contacts. Tests were repeated under different lighting and weather conditions to ensure robustness.

IX. DISCUSSION

The results confirm the feasibility of the proposed system. Using only embedded sensors and GSM keeps it simple while ensuring real-time detection. Unlike EPG or AI-based systems, this design is budget-friendly and easy to maintain. Deployment can be scaled by placing multiple sensor nodes along critical tracks.

GSM coverage is good in most areas; however, future versions can include LoRa or NB-IoT for remote regions.

X. CONCLUSION

This paper presents a cost-effective, IoT-enabled embedded system for monitoring fishplates and intrusions without using EPGs or AI. Tests show high accuracy and reliability.

The simple hardware and algorithms allow for easy deployment and maintenance, making it practical for large-scale use in developing countries.

XI. FUTURE WORK

Future improvements will focus on:

- Solar-powered operation for remote areas.
- Integration with long-range IoT protocols like LoRa.
- Web-based dashboards for live tracking.
- Data logging for preventive maintenance analysis.

ACKNOWLEDGMENT

The authors thank Lendi Institute of Engineering and Technology for the support and resources provided during the development and testing of this system.

REFERENCES

- [1] M. M. R. Nayan, et al., "An IoT-Based Real-Time Railway Fishplate Monitoring System," IEEE ICECE, 2020.
- [2] T. Pal, et al., "Low-Power Sensor Networks in Railway Infrastructure," IEEE Sensors Journal, 2021.
- [3] Ranjith et al., "IoT Based Obstacle Detection for Railways," International Journal of Engineering Research, 2019.
- [4] Y. Wang et al., "Fiber Bragg Grating Sensors for Rail Monitoring," IEEE Sensors Journal, 2018.
- [5] P. Sharma, et al., "Rail Track Fault Detection using IoT," International Journal of Advanced Research in Computer and Communication Engineering, 2018.
- [6] Verma and S. Jain, "Smart Railway Track Surveillance System," International Journal of Engineering Research & Technology (IJERT), 2019.

- [7] H. Liu et al., "Wireless Sensor Network for Railway Track Condition Monitoring," IEEE Internet of Things Journal, 2017.
- [8] V. Kumar and P. Kumar, "Railway Track Crack Detection using IoT," International Journal of Innovative Technology and Exploring Engineering (IJITEE), 2019.
- [9] S. Agarwal et al., "Real Time Railway Track Monitoring System using Internet of Things and Cloud," 2020 International Conference on Communication and Signal Processing (ICCSP).
- [10] P. H. Pathak and P. Mohapatra, "Railway Track Anomaly Detection using Wireless Sensor Networks," ACM Transactions on Sensor Networks, 2019.

